



Anderson Instrument Co., Inc.
 156 Auriesville Road
 Fultonville, NY 12072
 Phone: 518-922-5315 or 800-833-0081
 Fax: 518-922-8997 or 800-726-6733
 www.andinst.com

Technical Bulletin

SL/SX/LD/LA Liquid Level Transmitter Quick Start Installation Guide

Section 1 - Field Wireable Connector Assembly

1. Insert cable through Pressing Screw, Compression Ring, Seal Grommet, and Sleeve as shown below.
2. Strip back 1-1/4" of outer sheathing, cut off any excess wires, shield and ground. Strip off 1/4" insulation from remaining two wires. It is not necessary or recommended to tin the wires.

3. Orient Connector end so that center pin connecting screw is horizontal facing right (see detail).

CABLE REQUIREMENTS

- 2 conductor, stranded, 18-24 AWG, shielded with ground.
- 4-8mm (0.16-0.31") Cable Sheath

4. Wire LOOP+ (red) wire to top-right terminal, and LOOP- (black) wire to top-left terminal. No connection is made to the center and bottom terminals.

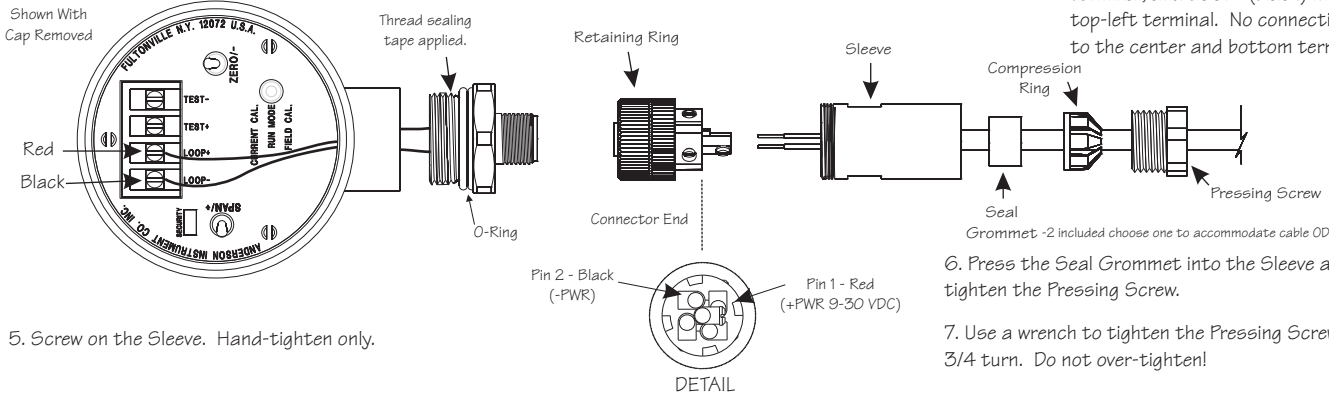

5. Screw on the Sleeve. Hand-tighten only.

6. Press the Seal Grommet into the Sleeve and hand-tighten the Pressing Screw.

7. Use a wrench to tighten the Pressing Screw another 3/4 turn. Do not over-tighten!

To install connector, simply line up key, press into receptacle, and hand-tighten the retaining ring.

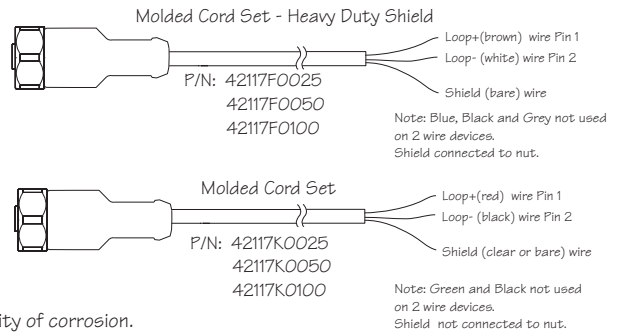
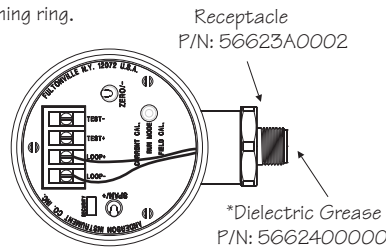

*Receptacle pins should be coated with USDA approved dielectric grease to minimize possibility of corrosion.

Section 2 - Proper Transmitter Wiring & Testing

- For units equipped with HART, HHT must be connected to loop. For detailed instructions see manual section 3.7. A Digital MultiMeter may be connected across Test+ and Test- to verify operation by observing the following readings:
1. 4 mA while vessel is empty. Value increases as level increases.
 2. 20 mA with MODE Switch in FIELD CAL position.
 3. Between 7.2 and 20 mA with MODE Switch in CUR CAL position. (The exact CUR CAL value indicates the calibration - see Sect. 4)

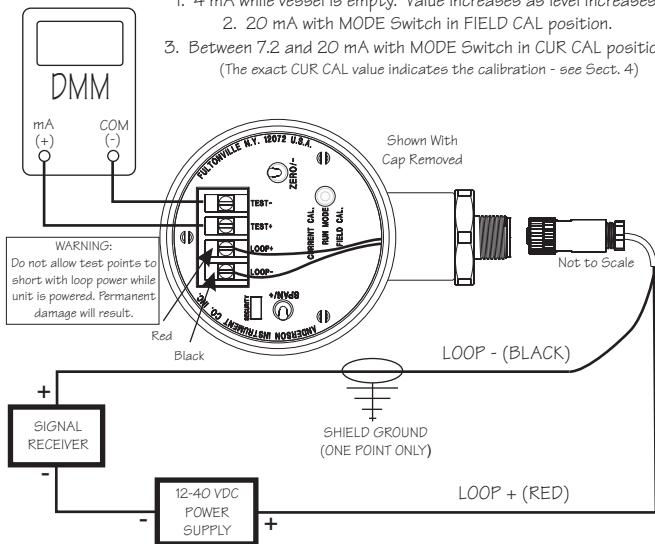

Section 3 - Sensor Rezero Procedure

Receiver and Meter Connections omitted for clarity. Meter may be used to verify 4.00 mA output, but is not required to perform Sensor Rezero Procedure.

- PROCEDURE MUST BE PERFORMED WHEN:
- Sensor is initially installed.
 - Whenever sensor is reinstalled in vessel.
 - About 1-2 months after initial installation.
 - Annually, as part of a PM program.

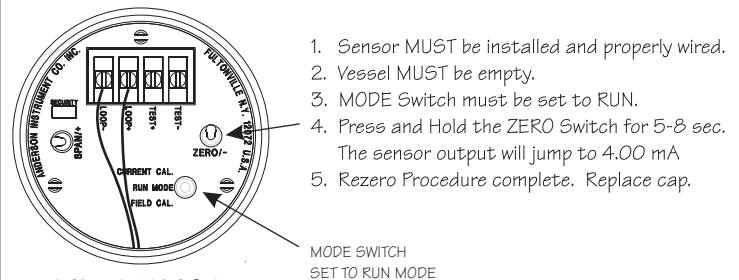

SWITCH FUNCTIONS:

- RUN: Normal Operating Mode, Rezero or Span with Pressure in Run Mode
- CURRENT CAL: Read CURRENT CAL Value with DMM Across Testpoints
- FIELD CAL: Program New CURRENT CAL Value with DMM Across Testpoints
- SPAN: Increase (+) Key while in FIELD CAL Mode, or Set Span with Pressure in Run Mode
- ZERO: Decrease (-) Key while in FIELD CAL Mode, or Set Zero with Vessel Empty in Run Mode

Section 4 - Calibration Verification

Anderson typically calibrates Level Transmitters specifically for the application for which it was intended. The factory calibrated value will be indicated by the last 5 digits of the sensor Model number to the nearest 1/10"WC (inches Water Column). All zeros indicate that the unit was not calibrated at the factory and that the unit would be calibrated in the field.

In the sample Model number: 5L5089100001234, the calibration is indicated by the "01234" as 20 mA @ 123.4"WC. Therefore, the sensor will output its full scale value of 20 mA at 123.4"WC pressure.

The specific calibration, or SPAN value of the level transmitter is programmable, and can be modified in the field. Since the SPAN is easily changed, we must verify that a sensor is properly calibrated to insure overall system accuracy. This is easily accomplished utilizing a Digital MultiMeter.

1. Determine the SPAN value as dictated by the Model # or the application.
2. Based on the first 3 digits of the sensor Model # determine the MAX CAL value.
 SL1/SL5/SX5/LD2/LA2 MAX CAL = 145 SL3/SL7 or SX7 MAX CAL = 835
 SL2/SL6 or SX6 MAX CAL = 420 SL4/SL8 or SX8 MAX CAL = 1390
3. Determine the CUR CAL value in mA by performing the mA translation calculation:

$$\text{CUR CAL} = ((\text{SPAN} / \text{MAX CAL}) \times 16) + 4\text{mA}$$
 Example: $((123.4 / 145) \times 16) + 4\text{mA} = 17.62\text{mA}$
 If provided as part of a system, the CUR CAL value may also be documented on a SYSTEM DATA SHEET.
4. Connect DMM as shown in Sect. 2. Move the MODE Switch to CURRENT CAL.
5. The displayed mA value should match the calculated CUR CAL value. If it does not, the sensor is not correctly calibrated and should be re-Spanned. Please refer to Section 3.5 of the SL/SX manual for this procedure.
 The manual is available on the web at: www.andinst.com

Section 5 - Troubleshooting Guide

AS TROUBLESHOOTING MAY CAUSE CHANGES IN SENSOR OUTPUT, SECURE ALL AUTOMATED CONTROLS PRIOR TO BEGINNING PROCEDURES

Most troubleshooting will require that you connect a Digital MultiMeter across the testpoints as indicated in Section 2. If you find that you need to contact the factory for assistance, please first record your findings in the spaces provided below.

- | | |
|--|---|
| <ol style="list-style-type: none"> 1. Tank Name: _____ 2. Sensor Model #: _____ 3. Sensor Serial #: _____ 4. Receiver/Display: _____ | <ol style="list-style-type: none"> 5. DC Voltage across LOOP+ & LOOP-: _____ 6. As found mA output when vessel empty: _____ 7. mA output after Rezero performed: _____ 8. mA output in CUR CAL Mode: _____ 9. mA output in FIELD CAL Mode: _____ |
|--|---|

SYMPTOM:

ACTION:

1. NO OUTPUT CURRENT (ZERO MA) IN ANY MODE:

Loop may be broken - Measure voltage across LOOP+ and LOOP- terminals. If not between 12-40 VDC, check connector and external loop wiring. Check if mA fuse in DMM is blown. This frequently occurs during testing.

2. CURRENT OUTPUT LESS THAN 4 MA AND DOES NOT INCREASE WITH LEVEL, OR IF MODE SWITCH SET TO FIELD CAL.

Connect milliammeter across LOOP+ terminal and TEST- testpoint. If loop now works, sensor circuitry has been damaged. Contact factory.

3. OUTPUT STUCK BETWEEN 4 AND 20 MA

Verify that MODE switch is in RUN mode. Empty vessel and perform Sensor Rezero Procedure as described in Section 3.

4. PERFORMING SENSOR REZERO PROCEDURE DOES NOT RETURN OUTPUT TO 3.96-4.04 MA

Verify that CUR CAL output is between 7.2 and 20 mA. If current is less than 4 mA, follow instructions for Symptom #2. If current is greater than 4 mA, sensor is damaged. Contact factory.

5. SENSOR OUTPUT IS NOT STABLE.

Verify that CUR CAL value is between 7.2 and 20 mA. Check for signs of moisture or water in housing. Contact factory.

6. OUTPUT DRIFTS OVER TIME.

7. SENSOR MA OUTPUT NOT AS EXPECTED FOR SPECIFIC LEVEL.

Perform Sensor Rezero procedure when vessel is empty. Verify proper CURRENT CAL output according to Section 4.

8. OUTPUT SIGNALS ARE NOT ACCURATE.

9. SENSOR OUTPUT IS GREATER THAN 20 MA.

Sensor may have been zeroed with product in the vessel. Perform Sensor Rezero Procedure as described in Section 3. Sensor may be over-ranged. Verify CUR CAL value, and that it is appropriate for the application. Contact factory for assistance.

10. SENSOR OUTPUT DOES NOT INCREASE WITH LEVEL, BUT DOES INCREASE TO 20 MA IF MODE SWITCH SET TO FIELD CAL.

Sensor may have been dropped or over-ranged and permanently damaged. Contact factory for assistance.