

Order Matrix Codes

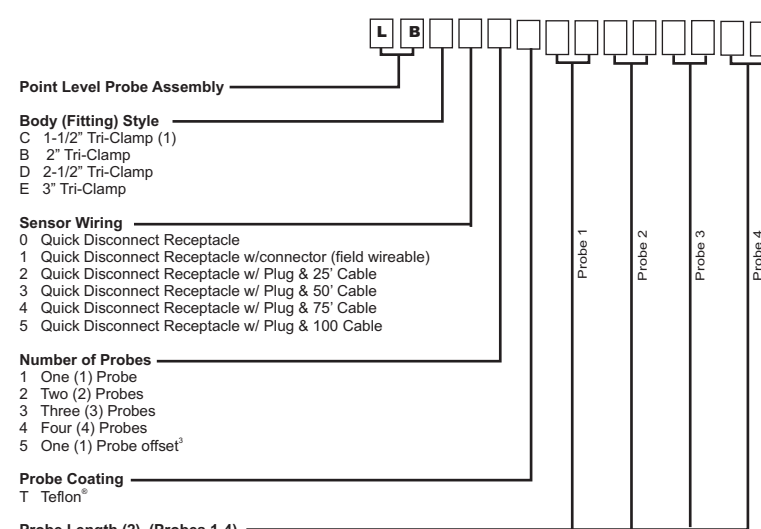
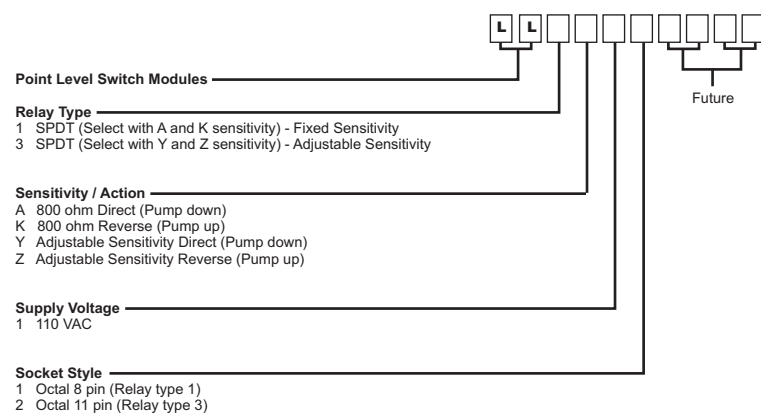
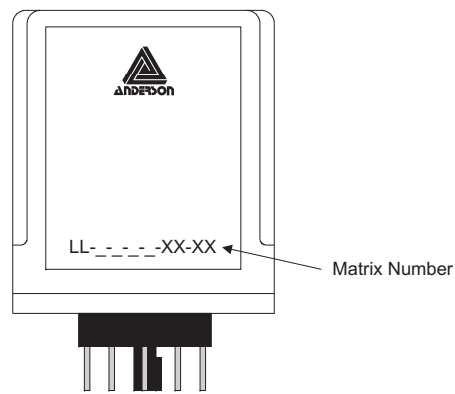

Notes:

- 1-1/2" Tri-Clamp available with one (1) or two (2) probes only.
- All standard probe lengths listed are available at standard lead times (consult factory). Probes may be specified to the nearest whole inch between 3" and 72" by simply inserting the length in the part number.
- Offset probe is available for 1-1/2" and 2" tri-clamp only. Probe offset from fitting: 1-1/2" = 0.34", 2" = 0.58"

Wiring for Multiple "Single Point" Service

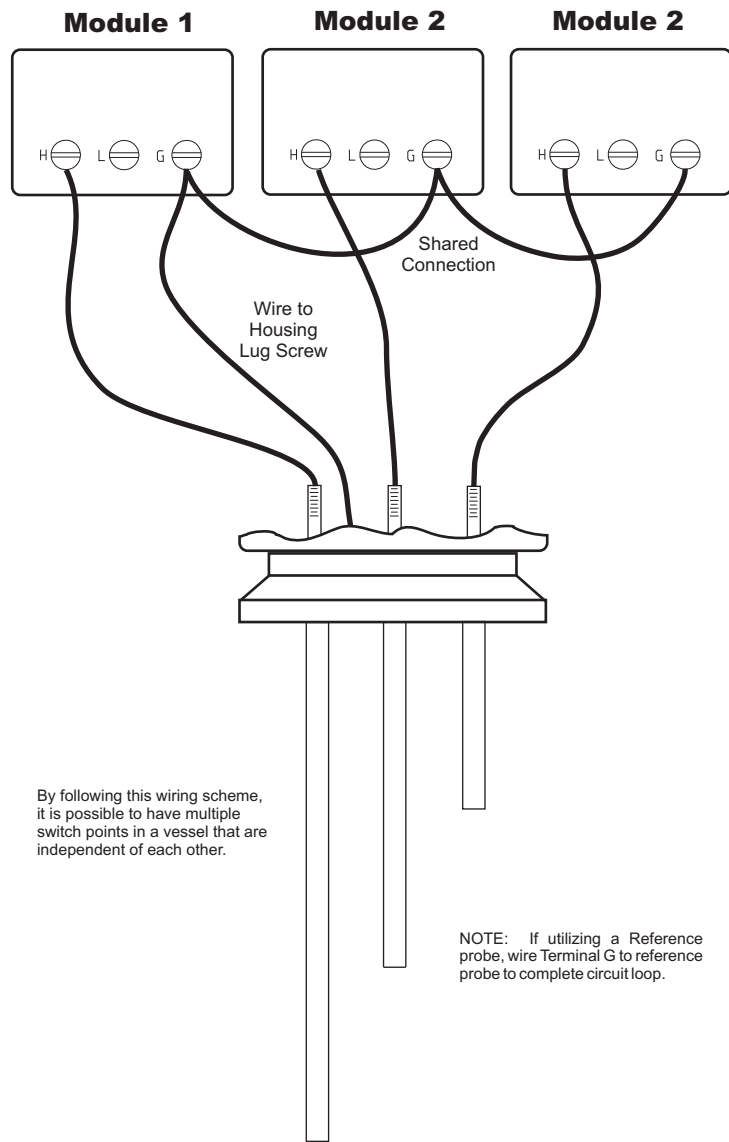

By following this wiring scheme, it is possible to have multiple switch points in a vessel that are independent of each other.

NOTE: If utilizing a Reference probe, wire Terminal G to reference probe to complete circuit loop.

NOTE - Alternate Wiring: It is also possible to connect switch module Terminal G to Earth Ground, with no connection to the housing lug screw. The active path will go from probe, through liquid medium, through vessel, through earth ground back into switch module completing circuit.

Path Of Completed Circuit (Example)

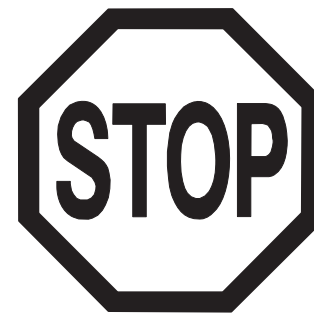
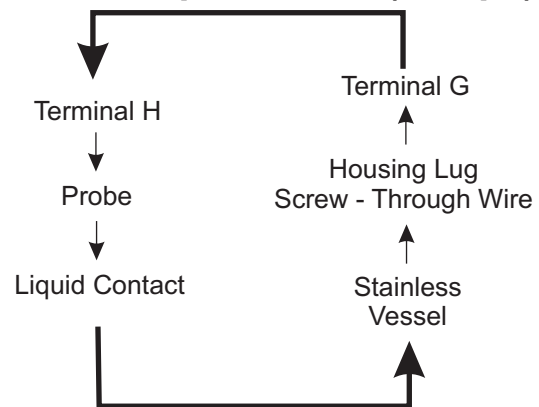

READ THIS FIRST

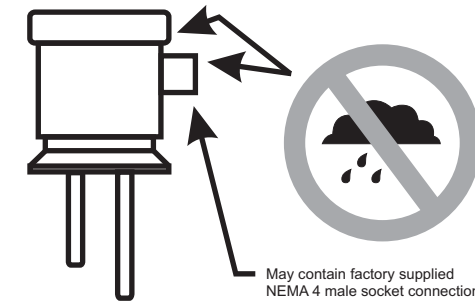

Be sure to keep moisture from entering the probe housing prior to completing field installation and startup. Upon installation, be sure no moisture path exists into housing. Properly seal all junction boxes, flexible conduit or customer supplied cable grips.



Anderson Instrument Co., Inc.
 156 Auriesville Rd. ~ Fultonville, NY 12072

Phone: 518-922-5315
 Fax: 518-922-8997

Reach us on the World Wide Web
www.andinst.com

This product carries a one (1) year warranty against manufacturers defects. A complete warranty statement is available by contacting Anderson, or in downloadable format from the World Wide Web.

Installation and Startup Guide

Model LB Conductivity Based Point Probe

Model LL Switch Module

Rev. 3.1 Document 1112

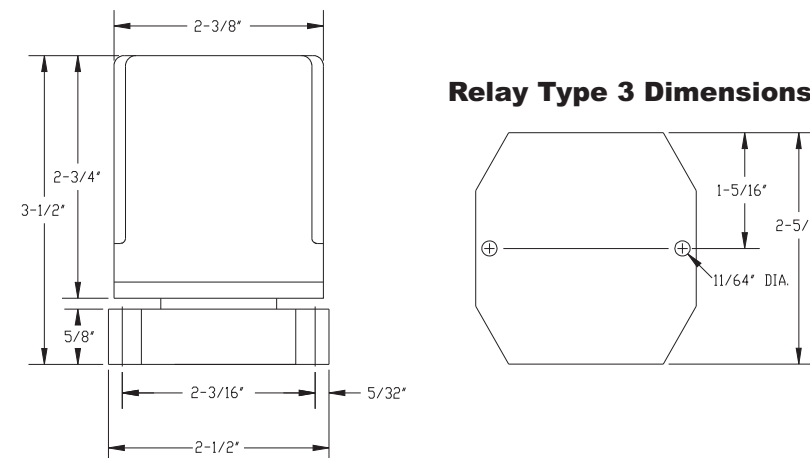
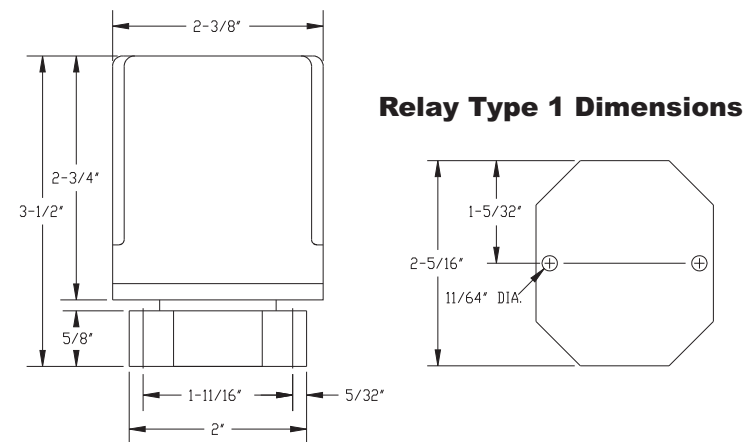

LL Switch Module Specifications

Control Design (Relay Type 1 & Type 3)
 Solid state components enclosed in clear Lexan plug-in style housing. Housing carries NO NEMA rating.

Contact Design (Relay Type 1 & Type 3)
 SPDT (1 for C): one normally open (N.O.) and one normally closed (N.C.) non-powered contacts

Contact Ratings (Relay Type 1 & Type 3)
 10A @ 240 VAC resistive, 1/3 HP @ 120,240 VAC

Contact Life (Relay Type 1 & Type 3)
 Mechanical 5 million operations. Electrical 100,000 operation at rated minimum load.

Supply Voltage (Relay Type 1 & Type 3)
 120 VAC (per model), plus 10%, minus 15%, 50/60Hz

Supply Current (Relay Type 1 & Type 3)
 120 VAC, Relay energized 4.4 VA.

Secondary Circuit (Relay Type 1 & Type 3)
 12 VAC RMS voltage on probes, 1.5 milliamp current.

Sensitivity (Relay Type 1)
 Operate from 0-1,000,000 ohm maximum specific resistance

Sensitivity (Relay Type 3)
 Operate from 0-1,000,000 ohm maximum specific resistance. Field adjustable.

Temperature (Relay Type 1 & Type 3)
 -40 to 150 deg F, ambient

Terminals (Relay Type 1 & Type 3)
 All connections #6-32 screw type terminals with pressure clamps

Time Delays (Relay Type 1 & Type 3)
 Standard, .5 seconds on rising level

Listing (Relay Type 1 & Type 3)
 U.L. listed, industrial Motor Control (508)

Probe Specifications

Material and Finish

Fitting and Probe: 316L grade stainless steel

Probe diameter (including coating): .44" diameter

Probe coating / insulation 0.03" min. thickness, FEP

Probe/Fitting Seal Food Grade, Elastomeric Compression Seals. 3-A and USP, Class IV compliant

Stainless steel and coating: Ra better than 25 micro-inches

Operational

Temperature Range 30 to 200 deg F (-1 to 94 deg C)
Vacuum or vented non-pressurized vessels

Pressure Range: -30" Hg to 100 psig

Compliance Ratings

- Assembly meets 3-A criteria for Sensors and Sensor Fittings and Connections (#74-01)
- Optional quick disconnect meets NEMA 4X requirements (In connected and dis-connected positions)

Typical Product Sensitivity Values

Baby Foods	1k	Molasses	10k
Beer	2.2k	Mustard	1k
Bourbon	200k	Oil Soluble	10k
Buttermilk	1k	Soap Foam	18k
Cake Batter	5k	Soups	1k
Catsup	2.2k	Starch Solutions	5k
Cream	1k	Sugar Solutions	90k
Cream (Foam)	4.7k	Vinegar Aqueous	2.2k
Coffee	2.2k	Carbonated Water	3k
Corn Syrup	45k	Condensated Water	18k
Corn Cream Style	2.2k	Chlorinated Water	5k
Jam / Jelly	45k	Distilled Water	450k
Juices Fruit / Veg	1k	De-ionized Water	2.0m
Mayonnaise	5k	Hard / Natural Water	5k
Milk	1k	Wine	2.2k

Note: Under normal conditions, select a module sensitivity just higher than appropriate for the product. For low sensitivity liquids (Milk / Cream), when foaming is normally present, use 800 ohm module sensitivity to ignore foam and 4.7K ohm to 5K ohm sensitivity to sense foam.

Each of the modules is supplied from the factory in a Direct or Inverse mode of operation. Referring to the product matrix descriptions, determine the mode of operation for your module. The following definitions explain the action that will occur with each of the specific modules.

SWITCH MODULE ACTION IS FACTORY SET, AND MAY NOT BE CHANGED IN THE FIELD

Direct Mode Operation (Pump Down) Single Level Service

When the liquid rises to the probe tip, the module energizes, changing the state of the load contacts. At this time, the internal LED will be lit. The module remains energized until the liquid recedes below the probe tip. The module then de-energizes, turning off the internal LED, and returning the switch contacts to their original shelf state.

Typical Operation: High level alarm

Inverse Mode Operation (Pump Up) Single Level Service

The module energizes with power, changing the state of the load contacts. At this time, the internal LED will be lit. When the liquid reaches the probe tip the module de-energizes, turning off the internal LED, and returning the switch contact to the original shelf state. The module remains de-energized until the liquid level recedes below the desired high switch point. The module then energizes, changing the state of the load contacts.

Typical Operation: Low level alarm

Direct Mode Operation (Pump Down) Differential Service

When the liquid rises to the "High" setpoint (probe on terminal 3) the module energizes, changing the state of the load contacts. At this time, the internal LED will be lit. The module remains energized until the liquid recedes below the "Low" setpoint (probe on terminal 4). The module then de-energizes, turning off the internal LED, and returning the switch contacts to their original shelf state.

Typical Operation: You have a vessel that you do not want to overfill, but also do not want to fall below a certain level. When the product reaches the level of the high probe, a pump is started to transfer product to another vessel. When the level recedes below the low probe, the pump stops.

Inverse Mode Operation (Pump Up) Differential Service

The module energizes with power, changing the state of the load contacts. At this time, the internal LED will be lit. When the liquid rises to the "High" setpoint (probe on terminal 3) the module de-energizes, turning off the internal LED, and returning the switch contacts to their original shelf state. The module remains de-energized until the liquid level recedes below the "Low" setpoint (probe on terminal 4). The module then energizes, changing the state of the load contacts.

Typical Operation: You have a vessel that you do not want to go empty. When you apply power to the module, the pump turns on and fills the vessel until you reach the level of the high probe. The pump then shuts off. If you fall below the level of the low probe, the pump will start again to keep the vessel filled.

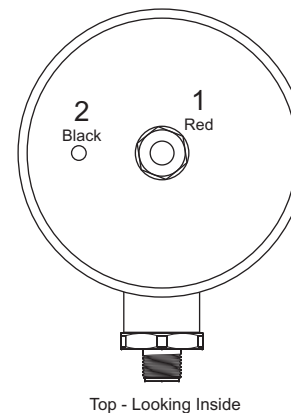

One Probe

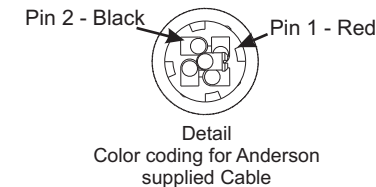

2 = Lug screw to housing
1 = Probe

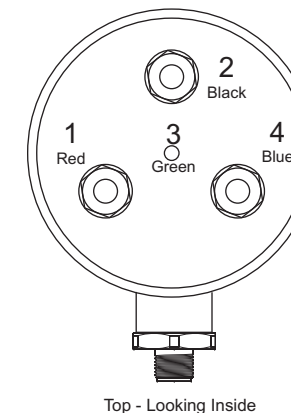

Three Probes

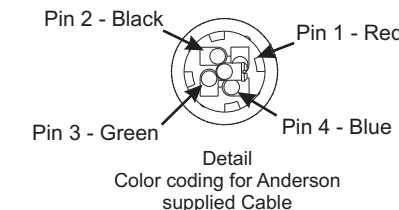

3 = Lug screw to housing
1 = Shortest Probe
2 = Next Longest Probe
4 = Longest Probe

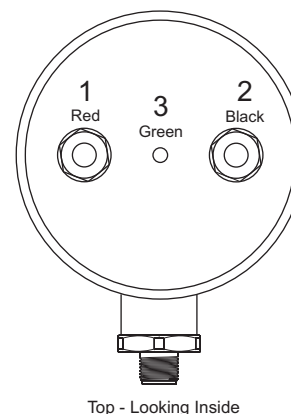

Two Probes

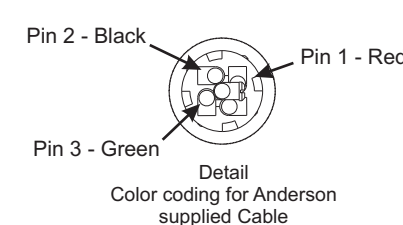

3 = Lug screw to housing
1 = Shortest Probe
2 = Longest Probe

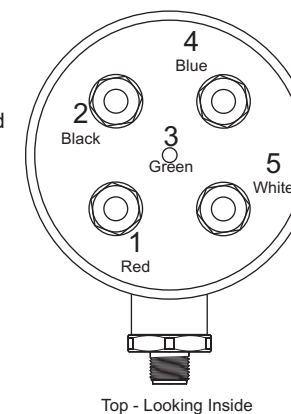

Four Probes

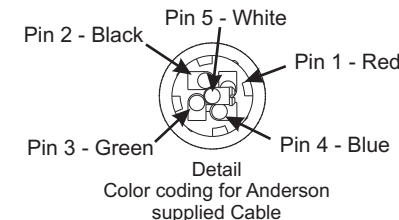

3 = Lug screw to housing
1 = Shortest Probe
2 = Next Longest Probe
4 = Next Longest Probe
5 = Longest Probe

If using a Type 3 Variable Sensitivity module, changes to the sensitivity may be made in the field. The following diagram shows placement for individual resistors. The following chart illustrates the resistor values used to achieve the desired sensitivity. Two resistors will be required for the value selected.

Sensitivity Required (Kohm)	Resistor Value Required (Kohm)
4.7	5.1
10.0	10.0
26.0	27.0
50.0	51.0
100.0	100.0
470.0	390.0
1,000.0	680.0

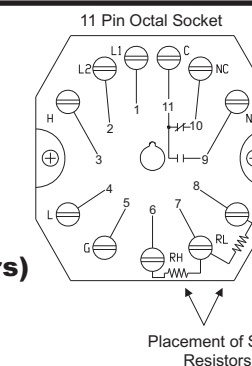

Adjustable Sensitivity (Utilizing add on resistors)

If using a variable sensitivity resistor board, installation is shown in figure 14. If two fixed resistors are already in place on the terminal screws of the socket, remove prior to installation of the variable resistor board.

Variable Resistor Board Part number: 56014R0070

Adjustable Sensitivity (Utilizing add on board)

The sensitivity range of the Variable Sensitivity Board is from 5K ohm to 700K ohm. These settings are achieved via the dual "One Turn" potentiometers located on the board. As the sensitivity increases in a non-linear ohm/turn ratio, you may use the chart shown above to achieve the proper setting.

BOTH potentiometers should be set to equal position for proper operation. Setting should be at approximately 5% greater than that necessary for the product in the vessel. You may refer to the chart shown in Figure 8 for sample sensitivity values.

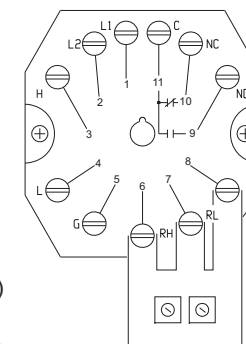
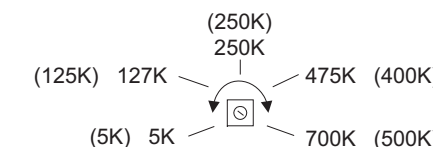

Module Type 1 Connection

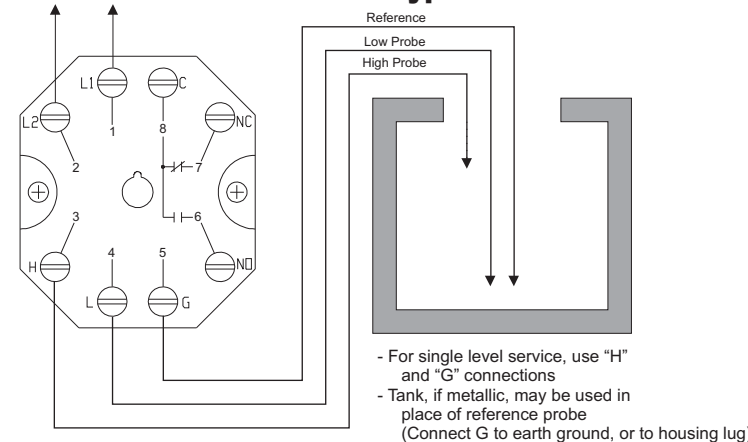

Module Type 3 Connection

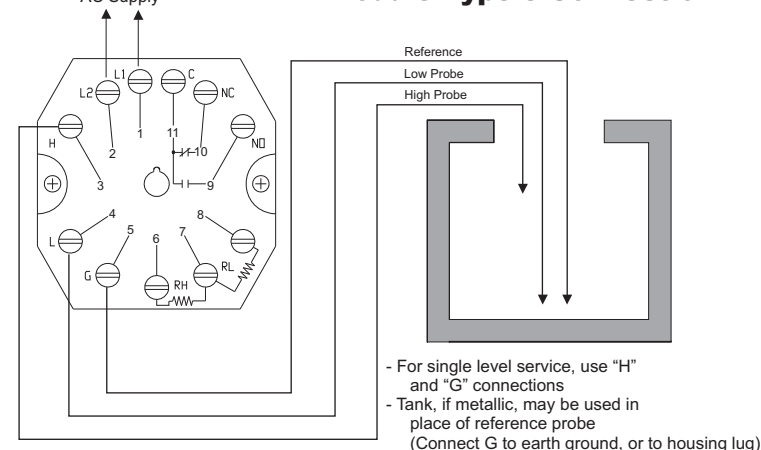

Field Modifications to Probe Lengths

Probe lengths are available in one-inch increments from 3" to 72". If a probe length must be field modified, consult Technical Service for proper guidelines and procedures.