



Form AIC1129 © 10/04
Effective: 10/1/08
Supersedes: 11/8/07

CERTIFIABLE DAIRY RECEIVING AND LOADOUT SYSTEMS

Application: In-line certifiable equipment for the measurement of dairy and food products utilized on an intake or load out function.

Issue: Existing methods of measurement do not provide the confidence that the quantity of product that is being paid for is actually representative of the quantity of product received. This brings into question whether the shrinkage within the processing plant is real, or is the product lost before the truck ever makes it to the plant? Several factors contribute to this situation, one of the most common is that bulk cooler stick readings have become unreliable due to a lack of regular accuracy verification, another is the inconsistency on the part of milk haulers in performing the stick readings and using a standardized procedure for the transfer of milk. Scales have always been affected by environmental influences such as snow, ice, and wind, which create errors in measurement, and the increase in the size of dairy farms has brought about the use of the trailer as the storage tank on the farm, eliminating the opportunity for a volume measurement at the farm and forcing reliance on truck scales, often times assuming vehicle tare weights.

Solution: Anderson Instrument offers a complete NTEP* listed dairy measurement system which fits within the confines of a dairy intake piping schematic. At the center of the system is the IZMS electromagnetic flowmeter, designed for use in dairy and food processing applications, the IZMS has the performance necessary to meet the stringent standards of a certified milk measurement system. A flowmeter alone cannot accomplish the job of milk receiving, and so the system also includes an air eliminator capable of protecting the measurement from product/air transitions, check valve, and a display with ticket printer. Together, these components are integrated with either a new or existing product pump to complete the system. The system can be configured for use as a product intake system or as a product load-out system and will satisfy the performance requirements for certification when properly installed by authorized Anderson Instrument installers and commissioned by Anderson factory personnel.

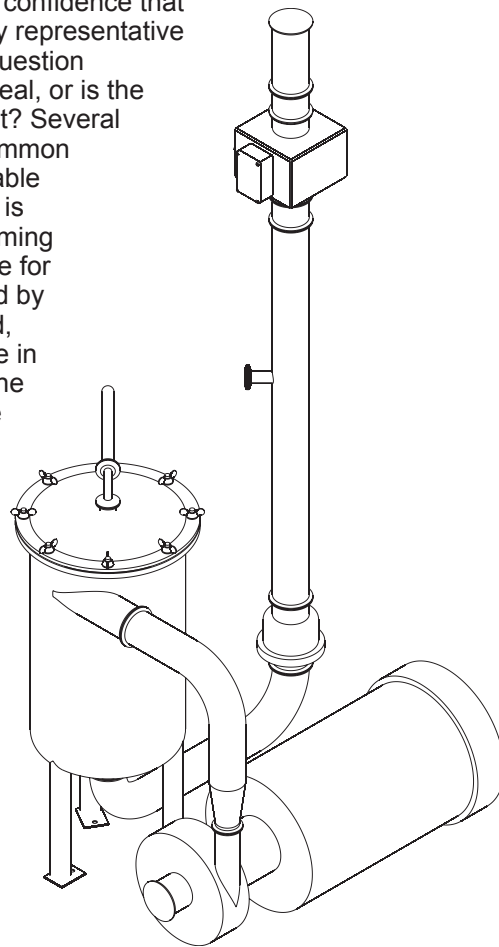

* National Type Evaluation Program

Specifications

Flow Ranges

Size	System Model #	Range
2"	CS2AE1IZS00T110	20-200 GPM
3"	CS3AE1IZS00T110	40-300 GPM
3"	CS3EA1IZS00T110	40-400 GPM

Accuracy: ± 0.15% acceptance
± 0.25% maintenance

Max Pressure: 65 psig CS(2/3)AE1IZS00T110
115 psig CS3EA1IZS00T110

Power Requirements: 115 VAC/230 VAC 50-60 Hz 2A

Construction

Flow Meter: 304 SS Housing
PTFE Liner
316L SS Electrodes
Connection box aluminum with corrosion resistant coating silicone elastomers

Air Eliminator: 304 SS
Buna gaskets and seals

Check Valve: 316L SS
Buna gasket

* Used in CS3EA1IZS00T110 system.

CS2AE1IZS00T110 CS3AE1IZS00T110

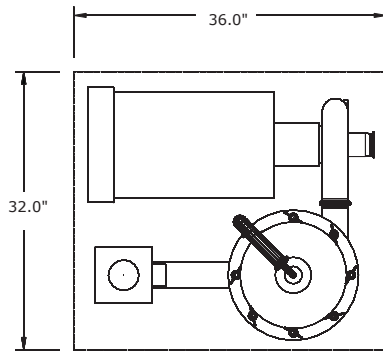

TOP VIEW
APPROXIMATE EQUIPMENT FOOTPRINT

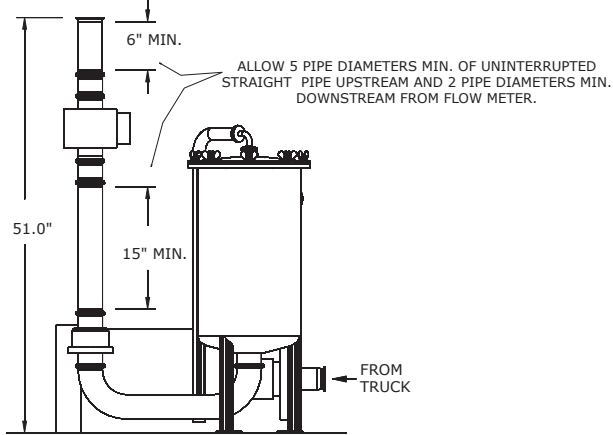

SIDE VIEW

CS3EA1IZS00T110

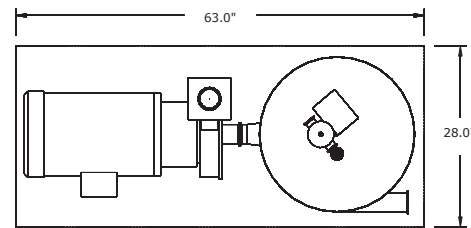

TOP VIEW
APPROXIMATE EQUIPMENT FOOTPRINT

ALLOW 5 PIPE DIAMETERS MIN. OF UNINTERRUPTED STRAIGHT PIPE UPSTREAM AND 2 PIPE DIAMETERS MIN. DOWNSTREAM FROM FLOW METER.

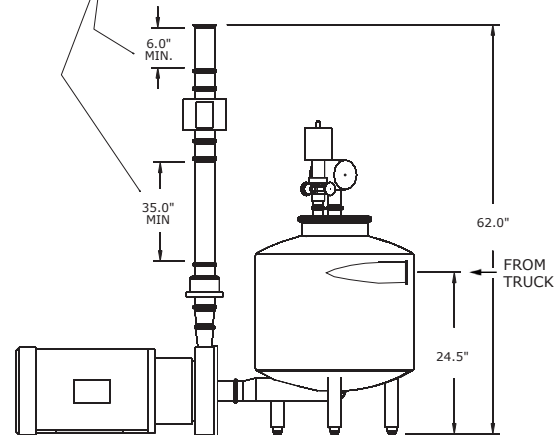

SIDE ELEVATION

ORDERING INFORMATION

DESCRIPTION	RANGE	PART NUMBER
2" System*	20-200 GPM	CS2AE1IZS00T110
3" System*	40-300 GPM	CS3AE1IZS00T110
3" System*	40-400 GPM	CS3EA1IZS00T110

* System includes: flowmeter, air eliminator, checkvalve, display with ticket printer, and 1 box of tickets.