



Anderson Instrument Co., Inc.
 156 Auriesville Road
 Fultonville, NY 12072
 Phone: 518-922-5315 or 800-833-0081
 Fax: 518-922-8997 or 800-726-6733

Technical Bulletin

LN Potentiometric Level Transmitter Quick Start Installation Guide

Section 1 - Field Wireable Connector Assembly

1. Insert cable through Pressing Screw, Compression Ring, Seal Grommet, and Sleeve as shown below.

2. Strip back 1-1/4" of outer sheathing, cut off any excess wires, shield and ground. Strip off 1/4" insulation from remaining four wires. It is not necessary or recommended to tin the wires.

3. Orient Connector end so that center pin connecting screw is horizontal facing right (see detail).

4. Wire PWR + (red) wire to top-right terminal, and PWR - (black) wire to top-left terminal. Wire LOOP + (white) to center terminal and LOOP - (green) to bottom left terminal.

5. Screw on the Sleeve. Hand-tighten only.

Shown With
 Cap Removed

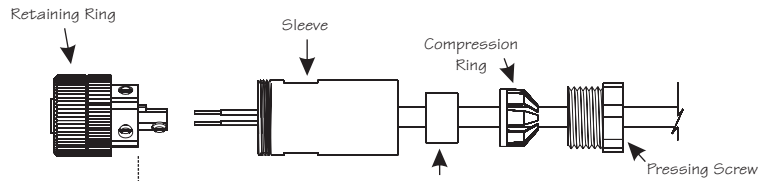
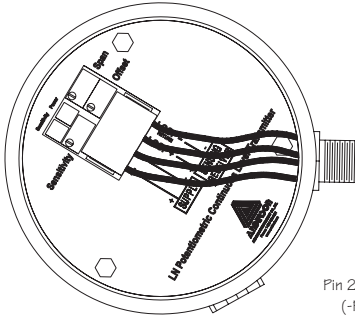

Seal Grommet-2 included choose one to accommodate cable OD

6. Press the Seal Grommet into the Sleeve and hand-tighten the Pressing Screw against the compression ring.

7. Use a wrench to tighten the Pressing Screw another 3/4 turn. Do not over-tighten!

CABLE REQUIREMENTS

- 4 conductor, stranded, 18-24 AWG, shielded with ground.
- 4-8mm (0.16-0.31") Cable Sheath OD.

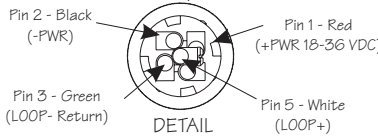

To install connector, simply line up key, press into receptacle, and hand-tighten the retaining ring.

*Receptacle pins should be coated with USDA approved dielectric grease to minimize possibility of corrosion.

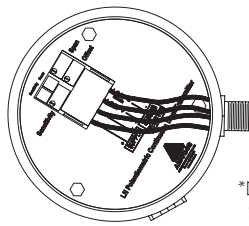

*Dielectric Grease
 P/N: 5662400000

Field Wireable Connector (assembled)
 P/N: 42119B0000 (without cable)

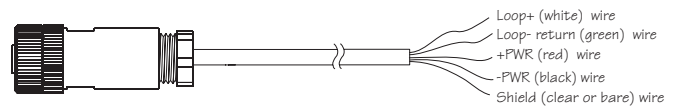

Molded Cord Set

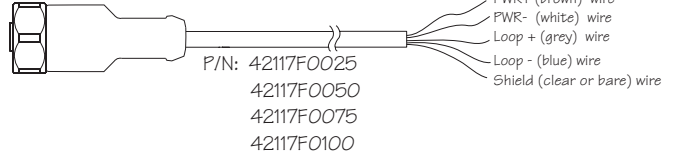

Section 4 - Installation / Calibration Verification

Operation

- Probe may not be cut! Trimming the probe length will disable the sensor and VOID warranty.
- The process connection must have electrical contact with the tank, therefore LN's must be clamped on fitting for proper operation.
- Single probe LN's are suitable for installation in linear metallic tanks with probe parallel to tank wall. Non-parallel installation will increase reading error.
- Dual probe LN's are suitable for installation in nonmetallic and/or non-linear tanks.
- Sensor probe must not touch tank wall.
- For accuracy and proper operation, measured media should be homogeneous with respect to temperature and conductivity. Media must have a conductivity of at least $1 \mu\text{S}/\text{cm}$.
- The LN is shipped calibrated to the bottom of the Teflon® coating. Normally at installation, additional adjustments are not required.
- A turndown of up to 30% below top of probe is possible if 20mA output is desired at less than full rod height. Follow SPAN ADJUST for this feature.

Calibration

Zero Adjust

- Connect power supply as shown in Section 1.
- Connect Digital MultiMeter to output. With empty vessel (uncovered probe) signal output is 2.4mA.
- Fill vessel until level contacts probe. Adjust OFFSET until signal output is 4.0mA (see Fig. 1).

Span Adjust

- Connect power supply as shown in Section 1.
- Connect Digital MultiMeter to output.
- Fill vessel until maximum level desired. Adjust SPAN until signal output is 20.0mA (see Fig. 1).

Note:

- Probe will not measure in Teflon® coated zone. Maximum level must be below the Teflon® zone.
- Max turn down is 30% of full probe length (including Teflon® coated area) from the top e.g. 30" rod length with 4" Teflon® coating may adjusted from 26" down to 21".
- Span and Zero are normally non interactive however significant turndown adjustment may require an additional Re-Zero step.

Sensitivity

Typically adjustment is not required. If calibration is needed, perform the following with the least conductive media:

- Connect power supply as shown in Section 1.
- Fill vessel until media level contacts probe.
- Observe red LED labeled SENSITIVITY (see Fig. 2 LN Sensitivity Table).
 - If the LED remains off or only blinks on briefly, turn SENSITIVITY clockwise.
 - If the LED remains on continuously, turn SENSITIVITY counterclockwise.

Note:

The objective is to achieve state 3 on the LN Sensitivity Table. The red LED should be lit with a brief off blink.

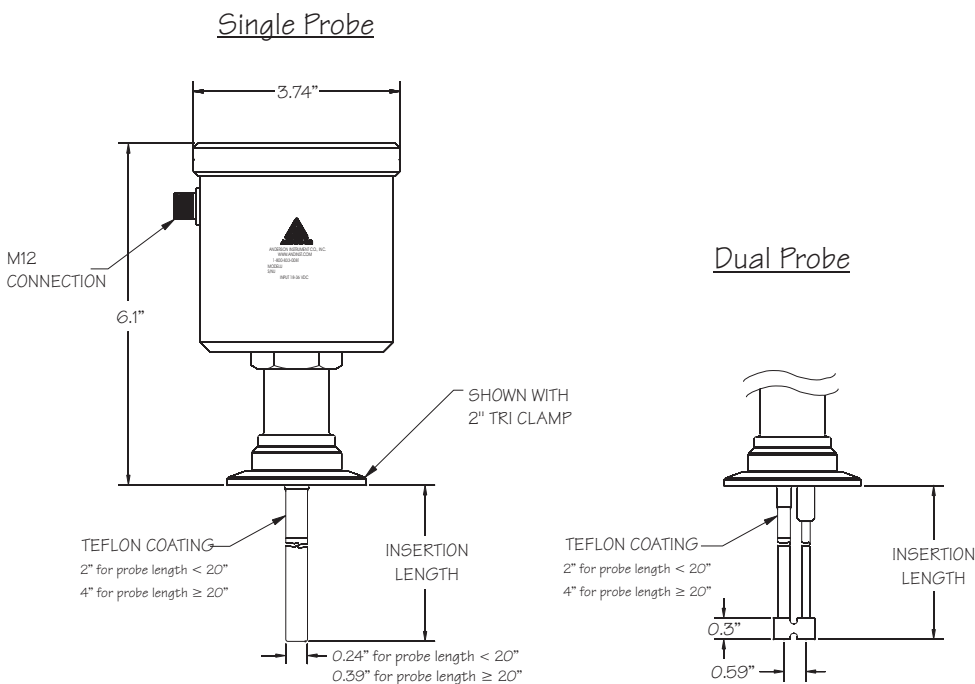

Figure 1

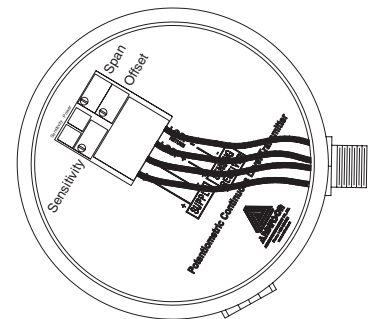

Figure 2

LN Sensitivity Table					
State	LED	OUTPUT	PROBE	SENSITIVITY ADJUSTMENT	EXPECTED
1	ON OFF	2.4 mA		DO NOT ADJUST	EXPECTED WITH NO LIQUID
2	ON OFF	4-20 mA		INCREASE SENSITIVITY	INCREASE SENSITIVITY
3	ON OFF	4-20 mA		DO NOT ADJUST	OPTIMAL
4	ON OFF	4-20 mA		DECREASE SENSITIVITY	TOO SENSITIVE