



READ THIS FIRST

Installation and Startup Guide

“MPF” Modular Pressure Transmitter

Version 2.0 Document 1182



Anderson Instrument Co., Inc.
156 Auriesville Rd., Fultonville, NY 12072
Phone: 518-922-5315
Fax: 518-922-8997

www.andinst.com

PRODUCT DESCRIPTION

The Anderson “MPF” Modular Pressure Transmitter is designed specifically for monitoring critical pressures in sanitary applications and environments. The modular design allows for field configuration to best suit application needs and allows economical component replacement. State of the art performance yields class leading accuracy and stability while minimizing process and ambient temperature effects. A menu driven interface with an internal diagnostic display provides user adjustability of pressure range and a host of other control characteristics without tools or pressure standards.

SENSOR WIRING

To facilitate electrical connections the MPF transmitter will be provided with either a 5 pin M12 quick disconnect receptacle, a M16 thread cable gland, or a 1/2” NPTF threaded adaptor. Shielded cable is recommended. See manual for additional detail.

Field wireable connectors or molded cordsets are available as accessories from Anderson Instrument.

FIELD WIREABLE CONNECTOR ASSEMBLY - ORDERED AS ACCESSORY

1. Insert cable through Pressing Screw, Compression Ring, Seal Grommet, and Sleeve as shown below.
2. Strip back 1-1/4” of outer sheathing, cut off any excess wires, shield and ground. Strip off 1/4” insulation from remaining two wires. It is not necessary or recommended
3. Orient Connector end so that center pin connecting screw is horizontal facing right (see detail).
4. Wire LOOP+ (red) wire to top-right terminal, and LOOP- (black) wire to top-left terminal. No connection is made to the center and bottom terminals.

5. Screw on the Sleeve. Hand-tighten only.

6. Press the Seal Grommet into the Sleeve and hand-tighten the Pressing Screw against the compression ring.
7. Use a wrench to tighten the Pressing Screw another 3/4 turn. Do not over-tighten!

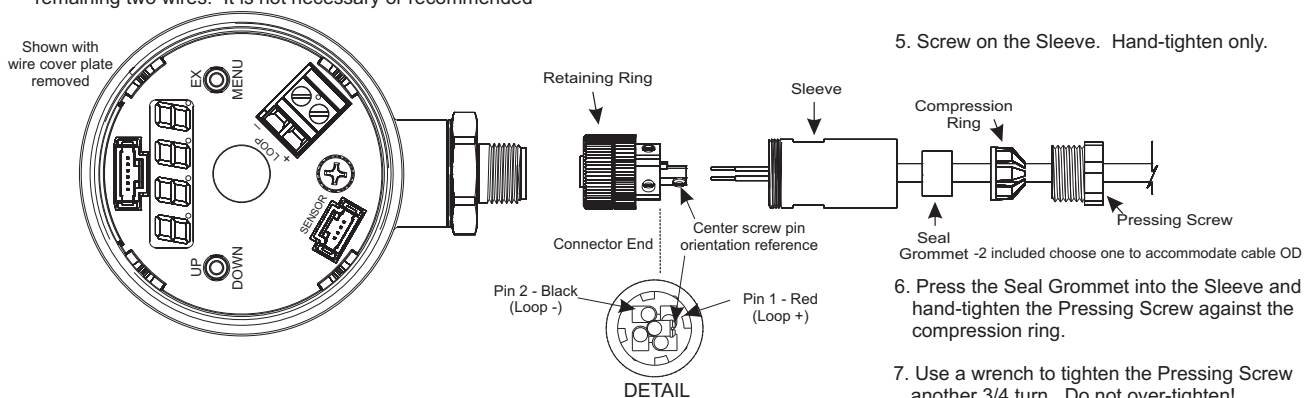

MOLDED CORD SETS

Anderson Cord Set

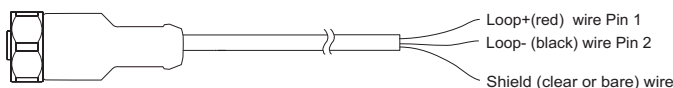

Typical Cord Set by others

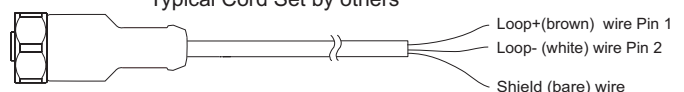

Note: Green and White not used

USER INTERFACE GUIDE

The Anderson "MPF" Modular Pressure Transmitter is factory calibrated to the URL (upper range limit) and configured to the range and units specified by the order matrix number. Range, pressure units, output damping and analog scale may be easily modified by the user. An internal 4 place LED provides user feed back for menu functions, displays diagnostic error codes and nominally loop current

The "MPF" Modular Pressure Transmitter configuration parameters are sorted into three modes, and are accessible via the two toggle switches located on either side of the internal display. While the cover is removed, do not allow moisture to enter the housing.

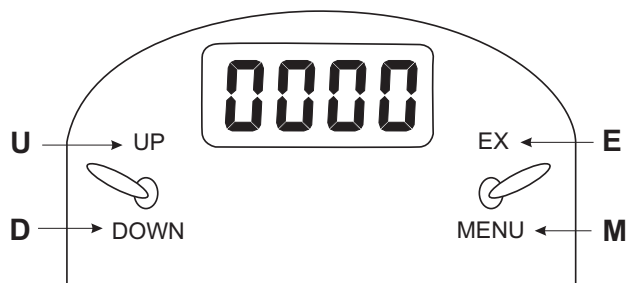

<u>RUN Mode</u>	<u>SENSOR CONFIG Mode</u>	<u>CALIBRATION Mode</u>
System diagnostics on startup Normal display reads loop current Diagnostic error codes enabled Quick rezero enabled NOTE: If on start up error message flashes, record error code, press and hold D for 1 second, re-power transmitter. If Error code persists refer to Maintenance/ diagnostic section of the manual	Set display mode - Current/process variable Set measurement units – Bar/PSI Set analog output – 4-20mA or 20-4mA Set LRV & URV Set damping Access factory restore	Custom range calibration NOTE: See manual for Calibration details

SENSOR CONFIGURATION

Each instruction assumes starting from RUN mode which is default at power on and milliamp output is displayed.

CALIBRATION – Zero

NOTE – For ABSOLUTE stems zero calibration is disabled as zeroing is not possible in atmospheric conditions.

Zeroing the sensor provides the best accuracy when clamped into the application therefore negates possible positioning and clamping errors. Be sure sensor is exposed to zero psig when performing this function.

1. Press both "D" and "M" simultaneously for approximately 5 seconds – Sensor displays 4.00 milliamp for gauge, for compound sensor displays appropriate output for set range

Display Mode: 4-20mA or process variable

1. Press "M" - Sensor displays "CONF"
2. Press "U" & "E" simultaneously for 2 seconds - sensor displays "CvAL" or "PvAL"
3. Press "U" or "D" - Sensor display toggles between "CvAL" or "PvAL"
4. Press "M" to proceed to next operation or if no other operation is to be accessed exit to "RUN" mode via pressing "M" repeatedly until milliamp or process variable output is displayed

Units: PSI or Bar

1. Press "M" – Sensor displays "CONF"
2. Press "E" – Sensor displays "PSI" or "BAR"
3. Press "U" or "D" – Sensor toggles between "PSI" or "BAR"
4. Press "M" to proceed to the next operation

Note: When changing units configuring range is now required

Output: 4Ma – 20Ma or 20mA – 4mA

1. Press “M” – Sensor displays “COntF”
2. Press “E” – Sensor displays “PSI” or “BAR”
3. Press “M” – Sensor displays “4-20” or “20-4”
4. Press “U” or “D” – Sensor toggles between “4-20” or “20-4”
5. If no other operation is to be accessed exit to “RUN” mode via pressing “M” repeatedly until milliamp output is displayed

PRESSURE RANGE

LRV: Lower range value

Sensors equipped with “Compound” style measurement cells (stem) may configure the LRV. “Gauge” and “Absolute” stems are predefined as 0 and are not reconfigurable

1. Press “M” – Sensor displays “COntF”
2. Press “E” – Sensor displays “PSI” or “BAR”
3. Press “M” – Sensor displays “4-20” or “20-4”
4. Press “M” – Sensor displays “LRV”
5. Press “E” – Sensor displays present LRV value – Example: “0”
6. Press “U” or “D” to set desired LRV value– Sensor display increases or decreases accordingly

Note: continue to URV

URV: Upper range value

Note: starting from LRV above

7. Press “M” – Sensor displays “URV”
8. Press “E” – Sensor displays present URV value – Example: “50”
9. Press “U” or “D” to set desired URV value – Sensor display increases or decreases accordingly
10. Press “E” to store displayed value – Sensor displays “URV”
11. If no other operation is to be accessed exit to “RUN” mode via pressing “M” repeatedly until milliamp output is displayed

Output Damping

1. Press “M” – Sensor displays “COntF”
2. Press “E” – Sensor displays “PSI” or “BAR”
3. Press “M” – Sensor displays “4-20” or “20-4”
4. Press “M” – Sensor displays “LRV”
5. Press “M” – Sensor displays “URV”
6. Press “M” – Sensor displays “dMPg”
7. Press “E” – Sensor displays current damping value from 0 - 10
8. Press “U” or “D” to display desired damping value– Sensor display increases or decreases accordingly
9. Press “E” to store displayed value – Sensor displays “dMPg”
10. If no other operation is to be accessed exit to “RUN” mode via pressing “M” repeatedly until milliamp output is displayed

Factory configuration reset

Perform if a return to the original factory configuration is desired

1. Press “M” – Sensor displays “COntF”
2. Press “E” – Sensor displays “PSI” or “BAR”
3. Press “M” – Sensor displays “4-20” or “20-4”
4. Press “M” – Sensor displays “LRV”
5. Press “M” – Sensor displays “URV”
6. Press “M” – Sensor displays “dMPg”
7. Press “M” – Sensor display “FrES”
8. Press “E” – Sensor display “nO”
9. Press “U” or “D” to display “YES”
10. Press “E” – Sensor display “FrES”
11. exit to “RUN” mode via pressing “M” repeatedly until milliamp output is displayed

EXPLODED VIEW

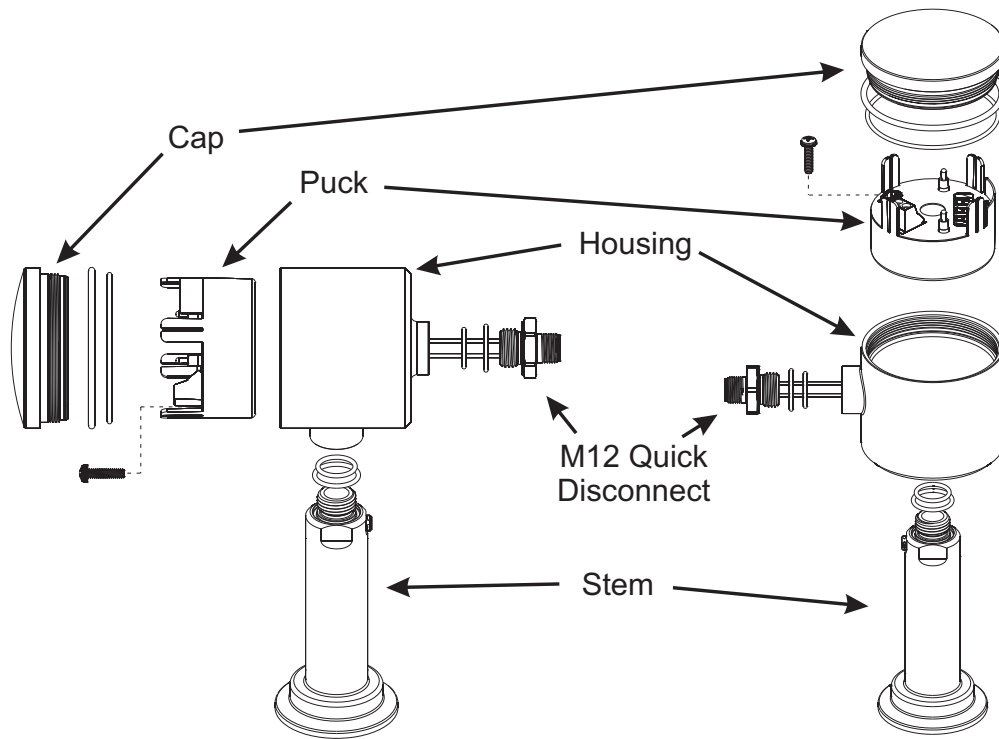

ACCESSORIES

Cord Sets

Shielded Molded w/25' cable 42117K0025
 Shielded Molded w/50' cable 42117K0050
 Shielded Molded w/100' cable 42117K0100

Clear Cap w/gaskets 5632800001
 Stainless Steel Cap w/gaskets 5632900001
 Enclosure w/Clear cap w/gaskets SP5632700001
 Enclosure w/SS cap w/gaskets SP56327A0001

M12 Quick Disconnect Receptacle SP56726A0002
 Cord Grip SP5633100000
 1/2" NPTF adaptor SP5633200000
 Seal Kit (6) gaskets 563300001
 Field Wireable Connector-Straight 42119B0000
 Field Wireable Connector-90° 42119A0000

DIMENSIONAL DRAWINGS

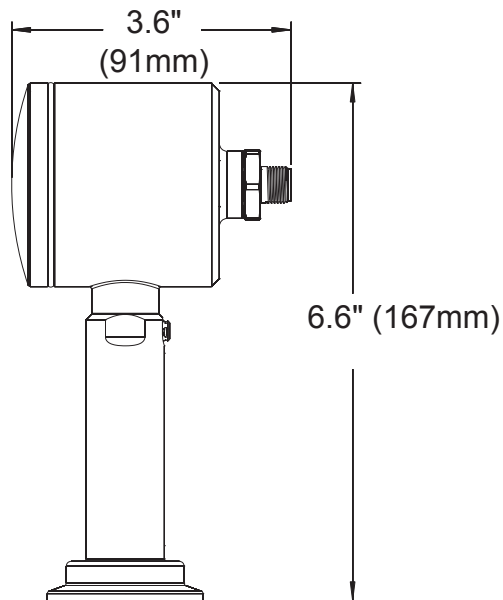

Horizontal Orientation

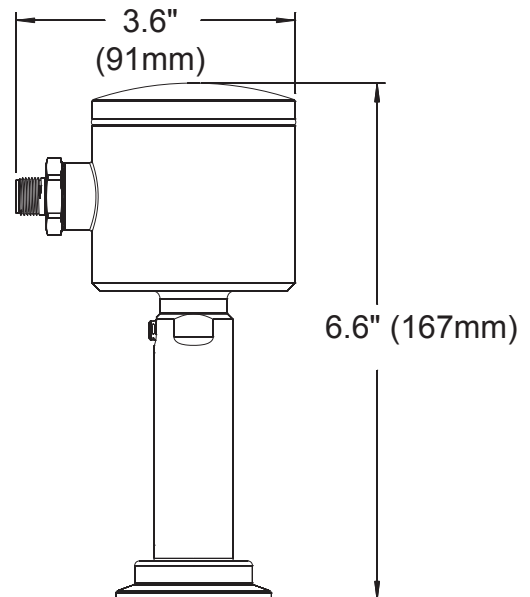

Vertical Orientation