



FLOW
LEVEL
PRESSURE
ANALYTICAL
TEMPERATURE
INSTRUMENTATION
PASTEURIZATION CONTROLS

PULSE 100 - SINGLE CHANNEL LIQUID LEVEL MONITOR

Display liquid level in single tank applications.

Continuous, high-visibility indication of liquid level in vessel and of high and low setpoint status.

Display shown in either gallons, pounds, liters, or kilograms.

Programmable for non-linear vessels.

User-friendly interface allows field programming of product parameters.

Panel or surface mounted enclosure.

The Pulse 100 microprocessor based monitor is designed for those customers wishing to monitor liquid level in a single vessel. The Pulse enclosure may be wall or panel mounted directly within the process, or control room environment. Visual indication of tank contents is provided via a 6 active digit LED display, giving optimum readout resolution regardless of measurement units. The single enclosure also houses the main microprocessor board, power supply and input/

output interface card slots. The Pulse 100 is supplied with a 4-20 mA input card, thus allowing direct hookup to Anderson liquid level sensors. Switching functions are provided via an optional plug in relay card, and allows for two active above, as well as two active below, switch points. In addition, 4-20 mA retransmission of the process signal may be accomplished via an optional plug in output card. Programming of system parameters such as tank span, offset, and product

specific gravity values may be accomplished utilizing the four momentary contact switches located on the interior of the unit. The unit may be programmed after installation to display either volume (gallons or liters) or weight (pounds or kilograms). A custom configured 100 point calibration reference table may be utilized to give true volumetric readings on non-linear vessels. The enclosure may be wall or panel mounted, up to 1200 feet from the vessel.

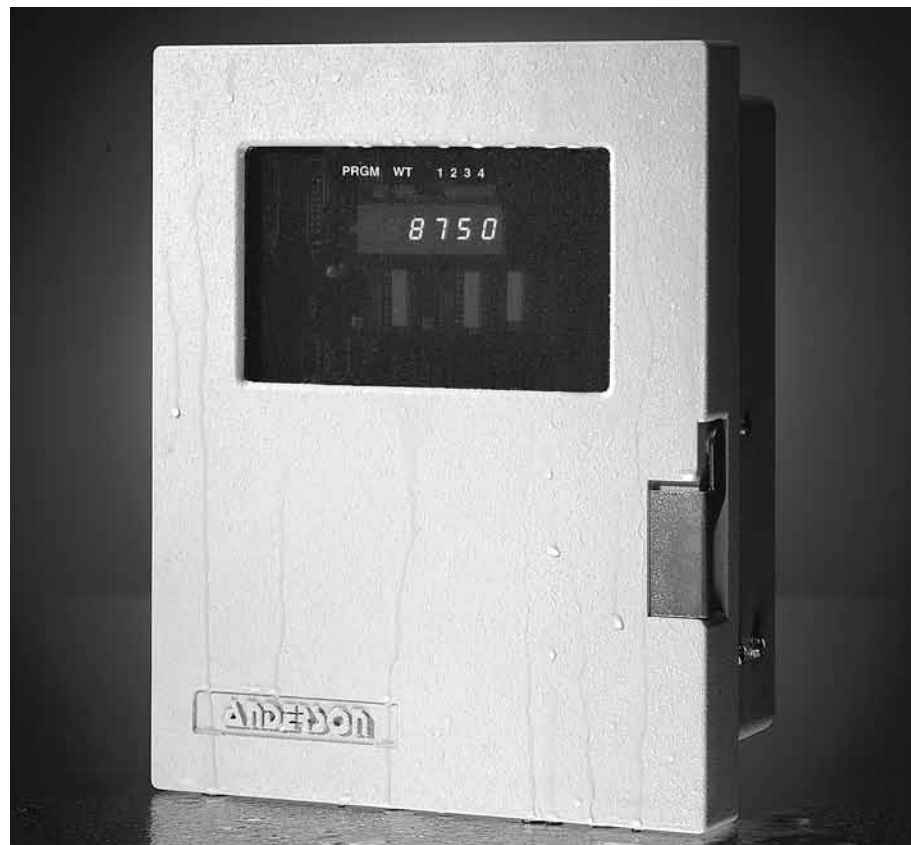

Pulse 100 Specifications

ENCLOSURE

Material: NORYL; painted
 Dimensions: 11 1/2" H x 9 1/4" W x 5 3/8" D
 Panel Cut out: 10 3/8" H x 8 1/16" W
 Rating: NEMA 4X
 Window Material: High impact polycarbonate
 Penetrations: 7/8" diameter, with rubber grommet
 LED Display: 6 active digits, .3" high, decimal point programmable. LED indication for volume/weight mode and alarm indication. Available in engineering units: gallons/lbs.; liters/kg

ENVIRONMENTAL

Operating Temperature Range: 32°F - 120°F (0°C - 50°C)
 Humidity: 5% - 95% non-condensing

INPUTS

Data Entry: Field configurable via four momentary contact switches and DIP switch bank. Supplied with 4-20 mA input card, 15 volt loop supply provided, current limited to 30 mA typical
 Accuracy: +/- 0.25% of calibrated span
 Stability: +/- .1% of span per 6 months

OUTPUTS

Relay: Optional, plug-in card, supplies 4 relays. Two active above setpoints, two active below setpoints.
 Contact Rating: SPST 120 VAC @ 1 Amp resistive max
 Relay Hysteresis: Programmable from 0-50% of span

Setpoint Range: Programmable
 Retransmission: Optional, plug in card
 Standard: Direct retransmission of 4-20 mA input signal
 Linearized: Retransmission of 4-20 mA signal linearized to tank and product parameters

OVERALL PERFORMANCE

System Accuracy: +/- 0.5% of full scale (Wet calibration may be required)
 System Stability: +/- 0.3% of span/6 months

POWER

Line Voltage (Standard): 115 VAC + 10% / - 15%; 50/60 Hz
 Line Voltage (Optional): 230 VAC + 10% / - 15%; 50/60 Hz
 Fuse Rating (115 VAC): 1/2 AMP Time Delay
 Fuse Rating (230 VAC): 1/4 AMP Time Delay
 Fuse Type: 1/4 x 1 1/4 3AG

Processor Board: Motorola 68HC11 HCMOS 8 bit microcomputer

HOW TO ORDER

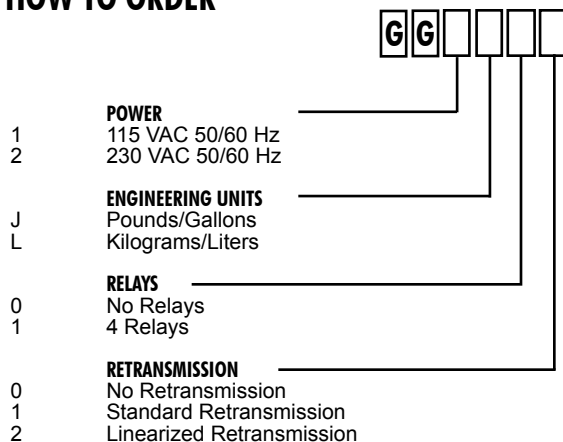

* Specify wall or panel mount