

Instruction Manual



Anderson Instrument Co. Inc.
156 Auriesville Road
Fultonville, NY 12072
1-800-833-0081
Fax 518-922-8997

Instrument Model Number _____

Instrument Serial Number _____

T-Series "SMART" Sanitary Pressure Transmitter



Form Number AIC3708
© April 1996
Revised: March 2010
Supersedes: February 2009

Table of Contents

	Page
Section 1 - Introduction	4
1.1 SPECIFICATIONS	5
1.2 DIMENSIONS	6
Section 2 - Theory of Operation	7
Section 3 - Installation	7
Section 4 - Sensor Wiring	8
Section 5 - Instrument Wiring	9
5.1 LOOP POWER	9
Section 6 - Liquid Crystal Display	10
6.1 LCD INSTALLATION	10
Section 7 - Maintenance	11
Section 8 - Calibration	11
8.1 CALIBRATION OF TRANSMITTER	11
8.2 CALIBRATION OF LCD DISPLAY	12
Section 9 - Troubleshooting	14
9.1 VOLTAGE CHECK	14
9.2 CURRENT CHECK	14
9.3 MISCELLANEOUS TROUBLESHOOTING	14
Section 10 - Warranty and Return Statement	16

Section 1 Introduction

This manual is provided to assist the user in installing, operating and maintaining the Anderson “T” Series transmitter. The “T” is a one-piece sanitary transmitter with digital communications capabilities. This digital communications capability is the feature which separates traditional analog transmitters from the new “SMART” devices which are becoming more popular for process monitoring and control. For more information on “SMART” and what it means to you, read the following:

Product Description: What is an Anderson “SMART Transmitter?”

An Anderson “T” Series transmitter is a second generation product developed on the proven RSP/RSV design platform. As such, it provides the user with an analog, 4-20 mA transmitter specifically designed to withstand the high ambient moisture, high vibration applications typical of Sanitary fluid processes. We’ve added a microprocessor-based circuit to enhance performance and provide local/remote communication capabilities. Customers benefit by being able to simplify specification, installation, start-up, and maintenance of their transmitters. We’ve chosen the “HART” protocol because of its broad acceptance in our core markets, and the flexibility and ease of use it provides our customers. HART stands for “Highway Addressable Remote Transducer”.

How do I communicate with the “SMART” Transmitter?

Communication is accomplished via a “HART” Hand-Held Terminal (HHT). The most current model the 275, was used in development of the “T” Series and will provide optimum performance and flexibility. Optionally, communication is possible via a P.C. interface.

Where do I connect the HHT in order to “talk” with my transmitter?

At any point where the signal leads from the transmitter are accessible. This could be at the transmitter itself, or at any connection point in the 4-20 mA loop.

What happens to the integrity of my 4-20mA signal while I’m connected via the HHT?

A distinct advantage to the HART protocol is the isolation between digital and analog signals. The 4-20 analog output remains intact while the HHT is connected!

What real life benefits will I realize by utilizing the “T” Series “SMART” transmitter?

In general, SMART transmitters offer immediate performance enhancements over their analog counterparts. Initial costs are slightly higher but this is countered by the time savings realized during commissioning and subsequent calibrations. With the Anderson “T” Series specifically, the calibration menu has been enhanced to provide direct access to the transmitter span adjustment. This allows the unit to be zero adjusted before installation and spanned on the process line, something competitive units can’t do. Also, Anderson’s HART protocol was developed as a universal set of menu’s, applicable to all pressure, temperature and level transmitters. This will insure that future product offerings will all communicate via one, common HHT.

1.1 SPECIFICATIONS

Ranges:	Defined by Upper Range Limit (URL)
Rangeability (Turn-down):	10:1 via any HART Host Device
Over Pressure Limit:	2X URL
Mechanical Trim Adjustments:	Internally adjustable $\pm 5\%$ of span (zero); $\pm 20\%$ of span (span)
Output:	4-20mA, Two-wire, Linear, Digital Process variable superimposed on 4-20mA signal, available to any "HART" protocol conforming host.
Power Supply:	13-40 volts, D.C. 18-45 volts, D.C. with display
Indication:	Optional, cap-mounted, LCD Indication accuracy $\pm 1\%$ F.S.
Temperature Limits (Process):	Standard/Direct Mount: 0 to 275°F (-18 to 135°C) High Temp/Direct Mount: 0 to 350°F (-18 to 177°C)** High Temp/Remote Mount 0 to 400°F (-18 to 204°C)**
Hazardous Locations Compliance:	MODEL TPP ONLY: UL Compliance with Class 1, Div. 1, Groups A thru D for intrinsically safe apparatus, when connected with approved barrier system (See instruction manual).
CE Compliance:	Transmitter complies with all CE requirements. Optional LCD display accuracy = $\pm 2\%$ when subjected to a radiated transmission field of 150 to 180 MHz, and 230 to 350 MHz (field strength of 10V/m 80% AM 1KHz).
Process Temperature Effect:	Less than 0.2% of full scale output/10°F change.
Performance Specifications:	
Accuracy* (psig ranges):	$\pm 0.2\%$ of URL
(psia, compound vacuum):	$\pm 0.3\%$ of URL
*Accuracy includes repeatability, hysteresis and linearity.	
Repeatability:	$\pm 0.06\%$
Hysteresis:	$\pm 0.07\%$
Linearity (BFSL):	$\pm 0.07\%$ ($\pm 0.17\%$ for psia, compound & vacuum ranges)
Stability:	$\pm 0.3\%$ of URL/6 months
Physical Specifications:	
Wetted Material:	316L Stainless Steel, Hastelloy "C" optional
Wetted Material Surface Finish:	MODEL TPP: R_a max = 8 microinches (.2 microns) and electropolished MODEL TFP: R_a max = 25 microinches (.6 microns)
Housing Material:	304 Stainless Steel
Electrical Connections:	1/2-14NPT conduit with screw terminals and integral test loops for HART interface

** Process vacuums in excess of 24" Hg may require slight de-rating of maximum temperature (consult factory).

1.2 DIMENSIONS

Figure 1 - Standard Direct-Mount

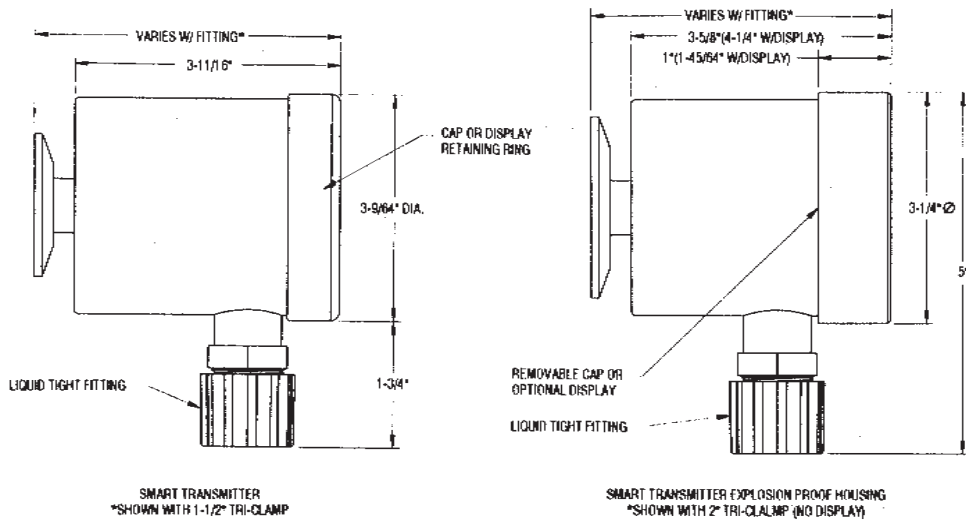

Figure 2 - High Temperature Direct-Mount

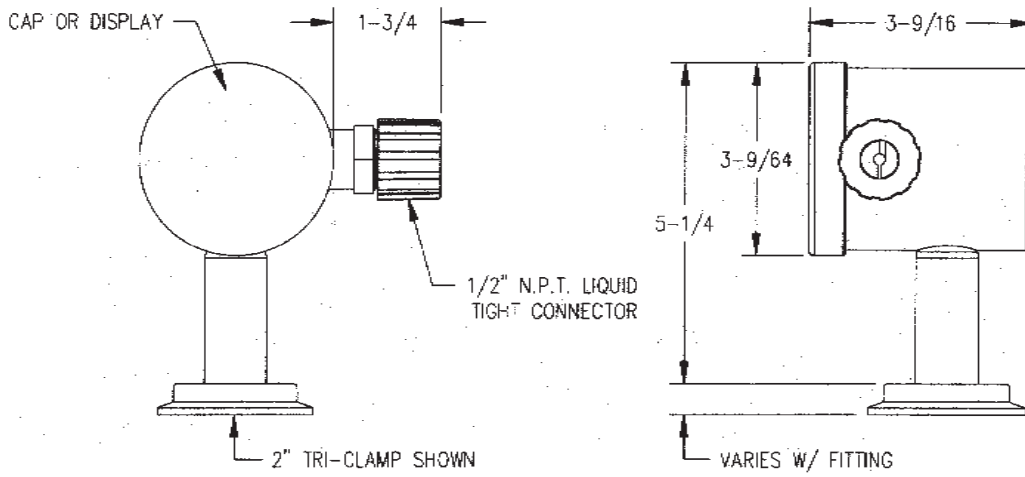
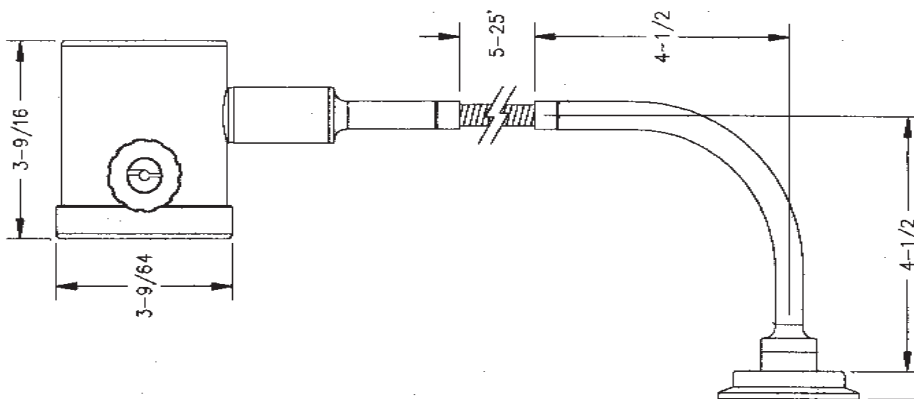

Figure 3 - High Temperature Remote-Mount



Section 2 Theory of Operation

The transmitter utilizes a sanitary diaphragm to transmit pressure to an electronic transducer. The output of this transducer is monitored by an on-board microprocessor which controls the signal level of the analog, 4-20 mA, output. The micro-processor also allows for remote communication which can be used in calibration, re-ranging, data storage, and troubleshooting the transmitter. The analog output remains interrupted during communication and as such can be used as an input to a recorder, controller, digital indicator, or PLC.

Section 3 Installation

The transmitter should be located on the process or equipment such that the housing is protected from physical abuse. Do not select a location where the unit can be struck by mobile equipment, forklifts, etc. The housing should be oriented such that the optional digital display is visible to the operator. A horizontal orientation may be optimum for viewing and also preferred if the process temperature will exceed 275°F (135°C).

Precautions should be taken to insure that the housing internals are not exposed to water, water vapor, or other moisture. Experience has shown that flexible conduits do not necessarily preclude water from entering sensor housings. Condensation is common within the conduit and must be kept from migrating into the sensor. Note: The installer assumes responsibility for preventing moisture from entering the sensor housing.

If mounted horizontally, the conduit fitting should point downward. The preferred method for connecting the sensor is to utilize the watertight connector provided to provide a seal against the cable. Rigid or flex conduit should be terminated just short of the sensor housing sealed as well to prevent water from migrating into the conduit. This method provides protection for the cabling, while isolating the sensor from water that inevitably finds its way into conduit runs.

Figure 4 - High Temperature Remote Mounting Diagrams

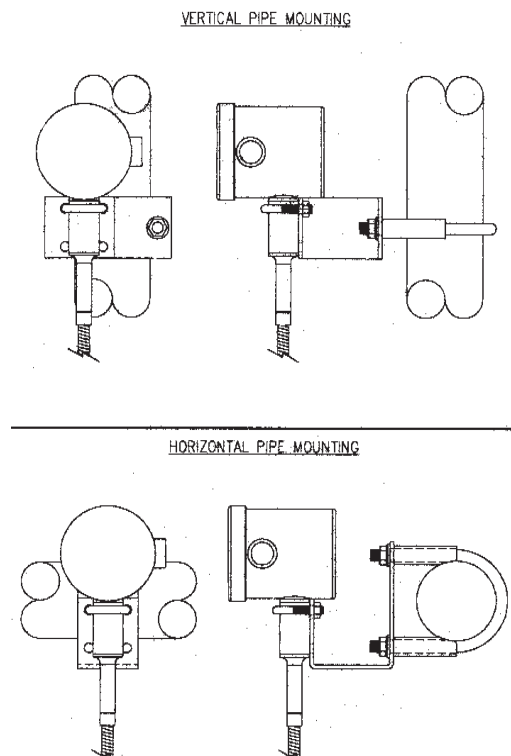

Section 4 Sensor Wiring

Anderson recommends a cable of 24 gauge, 4 conductor, shielded (Belden #9534) or equivalent. Four conductor cable is utilized because of its roundness, which provides a suitable seal when used with seal-tight connectors, strain reliefs and rubber grommets. Irregular shaped cable does not allow for a watertight seal.

If utilizing customer supplied cable, select a round cable with 22-24 AWG wire and a shield. In order for the Anderson provided seal-tight connector to seal on the cable, the O.D. of the cable must be between 3/16" and 1/4". If smaller cable is utilized, a different neoprene bushing must be used (must be customer supplied).

If an alternate seal-tight type connector is going to be used, be absolutely certain that the rubber bushing will adequately seal on the cable. Do not use a connector intended for power cable (large inside diameter) if the sensor cable is only 1/4". Be sure to use Teflon thread tape when attaching the new seal-tight connector.

Wiring to the conduit housing sensors is accomplished as follows:

1. Remove the housing cap to expose the wiring terminal block.
2. Insert the cable through the seal-tight connector, stripping back approximately 2 inches of sheathing to expose the wires.
3. Two wires will be utilized for connections at the transmitter end of the loop. Normal color codes being RED (Loop +) and BLACK (Loop -). Trim off all unused wires, including the bare shield ground wire. To prevent a GROUND LOOP condition, be sure the shield material and the shield ground wire do not touch the sensor housing. Use an insulator such as electrical tape or heat shrink tubing if necessary.
4. Strip the tips of the remaining wires back approximately 3/8 of an inch and twist strands (tinning is highly recommended).
5. Using Figure 5, make the proper connections to the wiring terminal strip (located inside the conduit housing)

Figure 5 - Wiring Terminal Connections

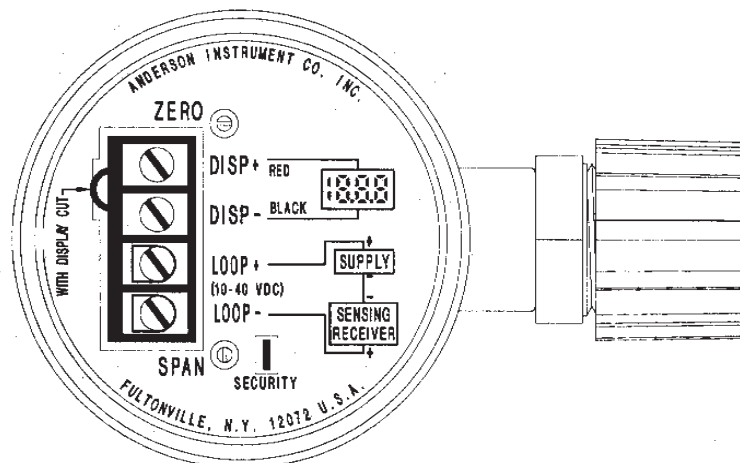

Section 5 Instrument Wiring

With the proper wiring connections made at the sensor end of the loop, it is now time to make final connections at the instrument end of the loop. The transmitter may feed instruments such as Anderson digital displays, microprocessor based controllers, chart recorders, or customer supplied instrumentation, or PLUS.

5.1 LOOP POWER

The Anderson SMART Transmitter requires loop power for operation. Ratings are as follows:

Standard "T" Transmitter: 12-40 VDC (Absolute), 24 VDC Nominal, regulated or unregulated

"T" Transmitter with LCD Display: 16-40 VDC (Absolute), 24 VDC Nominal, regulated or unregulated

As inherent resistance associated with cable length and signal receiver input may affect operation of the transmitter, Figure 6 shows some guidelines for loop power required.

NOTE: A minimum loop resistance of 250 ohms is required when communicating with the transmitter. This in turn requires that the power supply be rated at minimum 17 volts for nonindicating transmitters and 21 volts if an LCD display is supplied with the unit. The formulas for calculating maximum loop resistance for any rated power supply are as follows:

$$R_{max} \text{ (Without LCD)} = (V_{supply} - 12) \times 50$$

$$R_{max} \text{ (With LCD)} = (V_{supply} - 16) \times 50$$

Figure 6 - Loop Power Guidelines

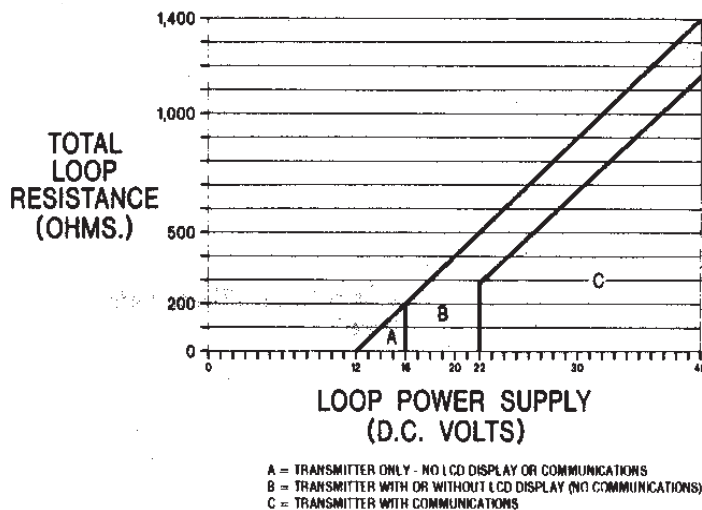

Please consult with the installation/service manual that was provided with your receiver for specific wiring instructions. Most Anderson receiver (displays, chart recorders, etc.) are capable of supplying loop power. Typical wiring would be as shown on following page.

Figure 7 - Loop Diagram

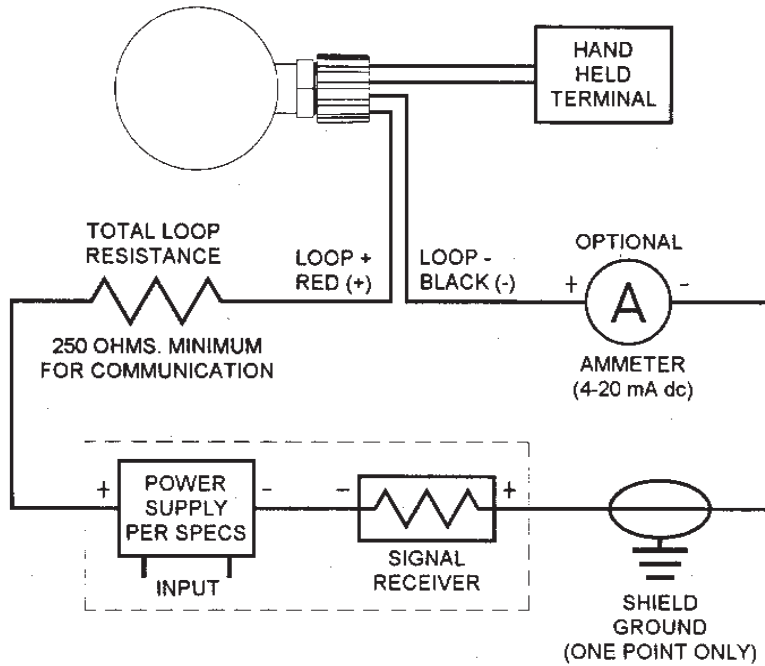

Section 6 Liquid Crystal Display

The “T” transmitter is available from the factory, or field upgradeable, with an integral LCD process display. The display is supplied from the factory pre-calibrated to the specified parameters.

NOTE: Although re-calibration may be performed, no alteration to the decimal point location may be made - this is a factory set function.

6.1 LCD INSTALLATION

Installation of an LCD Process Display into an already existing transmitter is as follows:

1. To prevent possible damage to the transmitter or receiver, it is recommended that all power be disconnected before proceeding.
2. Remove the conduit cap from the sensor. If upgrading a transmitter in the field, you will be supplied with a new conduit cap (hole in center).
3. To the left of the wiring terminal block will be a small YELLOW wire loop. It has an arrow pointing to it stating “WITH DISPLAY CUT”. Cut this loop, making sure the two ends don’t come in contact with each other or anything else.
4. Insert the LCD RED wire into the (DISP +) terminal and tighten.
5. Insert the LCD BLACK wire into the (DISP -) terminal and tighten.
6. Slide the LCD display into the end of the conduit housing, orienting for proper position.

7. Secure the new cap provided.
8. Apply power to the system.
9. At this point, check to be sure you are getting a proper reading. If the display is not active, immediately power down the loop and check your connections. If you feel the display is not reading properly, it may be necessary to perform calibration to the transmitter. Refer to Section 8 - Calibration.

Section 7 Maintenance

Anderson electronic sensors require very little maintenance, if any. We suggest that the sensor be inspected at 6 month intervals to ensure that they are not being physically abused, moisture is not entering the housing, and that the wiring is sound. Calibration may be checked, as required by SOP's, or when errors are suspected.

Section 8 Calibration

If you feel that the output of the transmitter is not correct, calibration of the unit may be required. This may be accomplished by following the procedure below, or via the "HART" HHT as outlined in the SMART INTERFACE Manual. Section 8.1 of this manual illustrates the procedures for calibration of the transmitter, with section 8.2 covering calibration of the LCD display.

Equipment required:

Pressure source
Accurate reference gauge
DC Milliamp Meter (accurate to .01 mA)
Small straight blade screwdriver
Calculator
mA Signal generator (helpful for LCD calibration)

8.1 CALIBRATION -TRANSMITTER

Adjustments to the transmitter are made via the "ZERO" and "SPAN" potentiometers. These two adjustments are non-interactive, meaning changing the zero will not change the span. As general maintenance to the unit, a zero check is recommended at approximately 6 month intervals. If your unit is calibrated at a compound range, you will not see 4.00 mA at atmospheric zero. As reference, you may use the following chart to determine if your unit may require calibration (most common ranges are shown).

NOTE: Use this procedure ONLY if the "HART" digital communications will not be utilized for calibration.

Sensor Range	Sensor Reads at Atmospheric Zero
0-psig - Positive Pressure	4.00 mA
0 psig - 30" Hg	4.00 mA
30" Hg - 15 psig	11.92 mA
30" Hg - 30 psig	9.26 mA
30" Hg - 60 psig	7.15 mA
30" Hg - 100 psig	6.05 mA

PAGE 12

The output of a properly calibrated transmitter may be calculated by using the following formula:

$$\text{mA Output} = 16 \times \frac{(\text{KNOWN VALUE} - \text{LOW END OF RANGE}) + 4}{\text{TRANSMITTER SPAN}}$$

NOTE: The transmitter should be wired in a complete loop at this point, or on a test bench and configured per the diagram shown in Figure 7, page 10. Although no interaction between zero and span occurs, when making adjustments you should be as close to the top and bottom transmitter range as possible. This will ensure the best possible linearity in the final signal output.

1. Expose the transmitter to a known zero reference point. If transmitter range starts at atmospheric zero, zero adjust at atmospheric zero. If transmitter is a compound range, you should be as close to sensor zero as possible. You must calculate the expected mA signal (use formula proved at start of this section).
2. Remove cap from transmitter.
3. With your meter set to DC mA, connect the RED (Meter +) lead to the (DISP +) terminal. Connect the BLACK (Meter -) lead to the (DISP -) terminal.
4. DO NOT USE THE LCD TO MAKE INITIAL SENSOR ADJUSTMENTS. If the LCD is not in calibration, an error will result in the calibration of the transmitter. The LCD should be calibrated separately. See Section 8.2, page 12 for proper procedures.
5. Adjust the transmitter ZERO potentiometer as shown in Figure 2, page 6, until you either see 4.00 mA if you are at atmospheric zero, or your expected mA signal for a compound range.
6. Expose the transmitter to a know process variable near the top end of the range.
7. Again, using the formula provided, calculate the mA reading expected
8. Adjust the transmitter SPAN potentiometer, shown in Figure 5, page 8, until you see your expected mA output.

NOTE: For pressure transmitters with compound ranges, the ranges must first be converted to all one type unit of measure. For example, a 30" Hg - 0-30 psig unit may be considered to have a range of -14.7 psig to 30 psig for a span of 44.7 psig (2.036" Hg - 1 psi). Be careful not to lose the - sign while performing the calculation of the proper reading.

8.2 CALIBRATION OF LCD DISPLAY

NOTE: Be sure the transmitter is in calibration before attempting to adjust the LCD display. The LCD reading is based on mA output from the transmitter. Therefore, if the transmitter is out of calibration, this error will be reflected in the LCD reading.

To perform calibration of the LCD display, you must first determine the Zero and Span. This information is on a sticker located on the back of the display. Adjustments are made via Zero and Span potentiometers, see Figure 5 for location. You may use either the HT transmitter itself to perform calibration of the display, or a 4-20 mA signal simulator.

CALIBRATION OF LCD USING 4-20 mA Simulator

1. Disconnect the LCD display from the transmitter by removing the RED and BLACK wires from their respective terminals.
2. Attach the POSITIVE lead of the simulator to the RED lead of the LCD display, and the NEGATIVE lead of the simulator to the BLACK lead of the LCD display.
3. The simulator should be set to POWERED output mode so that loop power is supplied. If your simulator is not capable of this function, wire two 9 VDC batteries in series with the 4-20 mA simulator, and the LCD display.
4. Apply 4.00 mA to the LCD display.
5. Adjust the ZERO potentiometer until the LCD matches the range indicated on the sticker in the spot labeled ZERO CALIBRATION.
6. Apply 20.00 mA to the LCD display.
7. Adjust the SPAN potentiometer until the LCD matches the range indicated on the sticker in the spot labeled SPAN CALIBRATION.
8. The LCD display is now properly calibrated. Re-wire the transmitter at this time:

CALIBRATION OF LCD USING TRANSMITTER/PROCESS

1. To complete this calibration, you must have a pressure source and a known accurate reference. AT this point you MUST be certain that the transmitter is in proper calibration. If necessary, start with section 8.1 - Transmitter Calibration, page 11.
2. Expose the transmitter to a known pressure near the LOW end of the calibrated range.
3. Adjust the potentiometer on the back of the LCD display labeled ZERO until the display matches your known reference.
4. Expose the transmitter to a known pressure near the HIGH end of the calibrated range.
5. Adjust the potentiometer on the back of the LCD display labeled SPAN until the display matches your known reference.
6. The LCD display is now properly calibrated.

Section 9 Troubleshooting

9.1 VOLTAGE CHECK

Using a digital multimeter on the DC volts scale and with the sensor connected to the receiver, confirm that the sensor is being provided the correct loop power. Place the RED (Meter +) lead on the (Loop +) terminal, and the BLACK (Meter -) lead on the (Loop -) terminal. You should see between 12-40 VDC for a standard transmitter, and between 16-45 VDC if you have an optional LCD display installed.

9.2 CURRENT CHECK

To check the mA loop, be sure the sensor is connected to the receiver. Open the cap on the transmitter to expose the wiring terminals. Using a digital multimeter on the mADC scale, connect the RED (Meter +) lead to the (DISP +) terminal and the BLACK (Meter -) lead to the (DISP -) terminal. You will be reading the mA current loop. A high current flow, approaching 30 mA, indicates a problem with the transmitter (internal source). If no current flow is observed this indicates either an open loop or a problem with the transmitter. To check a transmitter at a known pressure, refer to the Calibration section for information on how to properly calculate the mA output at the known value.

9.3 MISCELLANEOUS TROUBLESHOOTING

Symptom	Action
No display on receiver	<ul style="list-style-type: none">• Check loop for broken wire• Check receiver for power out (loop power)
Display on receiver reading improperly	<ul style="list-style-type: none">• Perform calibration check on transmitter• Perform calibration check on signal receiver
Transmitter not operating after LCD	<ul style="list-style-type: none">• Place a wire jumper from (DISP +) terminal to removed (DISP -) terminal
When testing Loop, NO current flow	<ul style="list-style-type: none">• Check for broken connections detected• Check loop wiring (incorrect polarity affects)

Feel free to contact Anderson Technical Services Department at 1-800-833-0081 for further assistance with troubleshooting.

Control Drawing

REVISIONS		44506C0001	
CHANGE NO.	DESCRIPTION	BY	DATE
A	95-022 RELEASED	DWG	9/30/96
B	00-017 ADDED TO MODEL # FOR HT DIR MT & RMT MT	TJG	2/25/00

HAZARDOUS AREA
CLASS I
GROUPS A, B, C, D

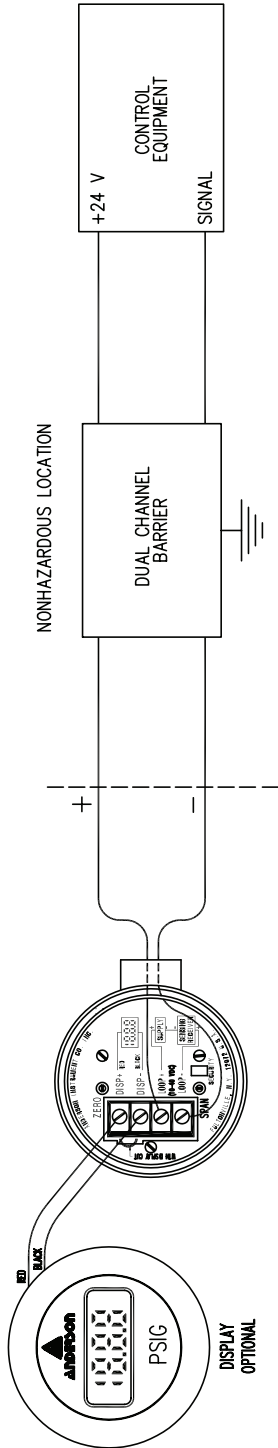

MODEL NUMBERS

I - P - P - 0 - 1 - 1 - 1 - 002 - 1 - 1 - 1 - 0 - 000
 THRU THRU THRU THRU THRU THRU OR G THRU
 3 2 6 123 2 A A 999
 THRU B
 Q R Q

- NOTES:**
- SEE OPERATING INSTRUCTIONS.
 - ASSOCIATED APPARATUS MUST NOT BE CONNECTED IN PARALLEL UNLESS PERMITTED BY THE ASSOCIATED APPARATUS APPROVAL.
 - WARNING - SUBSTITUTION OF COMPONENTS MAY IMPAIR INTRINSIC SAFETY.

TRANSMITTER ENTITY PARAMETERS

V max = 40 VDC
 I max = 165 mA
 P max = 1 W
 Ci = 0.01 uF
 Li = 0 uH

NOTES ON BARRIERS

- MAY BE IN A DIVISION 2 LOCATION IF SO APPROVED.
- OUTPUT CURRENT MUST BE LIMITED BY A RESISTOR SUCH THAT THE OUTPUT VOLTAGE-CURRENT PLOT IS A STRAIGHT LINE DRAWN BETWEEN OPEN CIRCUIT VOLTAGE AND SHORT CIRCUIT CURRENT.
- CABLE CAPACITANCE PLUS INTRINSICALLY SAFE EQUIPMENT CAPACITANCE MUST BE LESS THAN THE MARKED CAPACITANCE (Cg) SHOWN ON ANY BARRIER USED. THE SAME APPLIES FOR INDUCTANCE. CAPACITANCE AND INDUCTANCE OF FIELD WIRING FROM THE TRANSMITTER TO THE BARRIER SHOULD BE CALCULATED AS (Cc = 60pF/FT AND Lc = 0.2uH/FT) AND SHOULD BE INCLUDED IN THE SYSTEM CALCULATIONS.
- SELECTED BARRIERS MUST BE THIRD PARTY APPROVED AS INTRINSICALLY SAFE FOR THE APPLICATION AND HAVE Vcc OR Vi NOT EXCEEDING Vmax AND Isc OR IT NOT EXCEEDING Imax AND THE Pmax OF THE BARRIER MUST BE LESS THAN OR EQUAL TO THE Pmax OF THE TRANSMITTER AS SHOWN FOR EACH TYPE OF BARRIER IN TABLE 1.
- BARRIERS MUST BE INSTALLED IN ACCORDANCE WITH BARRIER MANUFACTURERS CONTROL DRAWING AND ARTICLE 504 OF NATIONAL ELECTRICAL CODE ANSI/NEPA 70.

NOTES ON CONTROL EQUIPMENT

- MAINS POWER MUST NOT EXCEED 250 VOLTS WITH RESPECT TO EARTH.

TABLE 1

Equipment	Barrier
V max	≥ Voc
I max	≥ Isc
P max	≥ P max
CI+Cc	≤ Ca
LI+Lc	≤ La

IF Pmax OF BARRIER IS NOT KNOWN IT MAY BE CALCULATED USING THE FORMULA Voc X Isc = Pi

PROPRIETARY INFORMATION

THE INFORMATION CONTAINED HEREON IS CONFIDENTIAL AND MAY NOT BE COPIED OR DISCLOSED TO OTHERS WITHOUT WRITTEN CONSENT FROM ANDERSON INSTRUMENT CO., INC.

THIS DRAWING IS THE PROPERTY OF
 Anderson Instrument Co. Inc.
 156 Ardenville Rd., Fultonville, New York 12072 USA

SCALE: NONE
 DRAWN BY: DWG 5/22/96
 CHECKED BY: -N/A-
 MATERIAL: -N/A-
 FINISH: -N/A-

*** UNLESS OTHERWISE SPECIFIED ***
 ALL DIMS. ARE IN INCHES. BREAK CORNERS .015 MAX.
 ALL SURFACES RY.
 REMOVE ALL BURRS

Tolerances or:
 3 P.L.C. DEC. ±.004
 2 P.L.C. DEC. ±.010

FRACTIONS 1/64
 ANGLES 1/4°

R & D DWG NO. 44506C0001
 SHEET NO. DWG. 15 OF 15
 REV. B

Section 10

Warranty and Return Statement

These products are sold by The Anderson Instrument Company (Anderson) under the warranties set forth in the following paragraphs. Such warranties are extended only with respect to a purchase of these products, as new merchandise, directly from Anderson or from an Anderson distributor, representative or reseller, and are extended only to the first buyer thereof who purchases them other than for the purpose of resale.

Warranty

These products are warranted to be free from functional defects in materials and workmanship at the time the products leave the Anderson factory and to conform at that time to the specifications set forth in the relevant Anderson instruction manual or manuals, sheet or sheets, for such products for a period of two years.

THERE ARE NO EXPRESSED OR IMPLIED WARRANTIES WHICH EXTEND BEYOND THE WARRANTIES HEREIN AND ABOVE SET FORTH. ANDERSON MAKES NO WARRANTY OF MERCHANTABILITY OR FITNESS FOR A PARTICULAR PURPOSE WITH RESPECT TO THE PRODUCTS.

Limitations

Anderson shall not be liable for any incidental damages, consequential damages, special damages, or any other damages, costs or expenses excepting only the cost or expense of repair or replacement as described above.

Products must be installed and maintained in accordance with Anderson instructions. Users are responsible for the suitability of the products to their application. There is no warranty against damage resulting from corrosion, misapplication, improper specifications or other operating condition beyond our control. Claims against carriers for damage in transit must be filed by the buyer.

This warranty is void if the purchaser uses non-factory approved replacement parts and supplies or if the purchaser attempts to repair the product themselves or through a third party without Anderson authorization.

Returns

Anderson's sole and exclusive obligation and buyer's sole and exclusive remedy under the above warranty is limited to repairing or replacing (at Anderson's option), free of charge, the products which are reported in writing to Anderson at its main office indicated below.

Anderson is to be advised of return requests during normal business hours and such returns are to include a statement of the observed deficiency. The buyer shall pre-pay shipping charges for products returned and Anderson or its representative shall pay for the return of the products to the buyer.

Approved returns should be sent to: ANDERSON INSTRUMENT COMPANY INC.
156 AURIESVILLE ROAD
FULTONVILLE, NY 12072 USA

ATT: REPAIR DEPARTMENT