



P R E S S U R E  
T E M P E R A T U R E  
L E V E L  
I N S T R U M E N T A T I O N  
F L O W  
A N A L Y T I C A L

## "Mini" Sanitary Pressure Gauge

- *The only sanitary gauge that mates directly on 3/4" and 1" lines*
- *Autoclaveable w/CPM fitting*
- *Lowest profile of any "mini" gauge*
- *Minimal temperature effect*
- *Re-zero feature is standard*

Anderson is pleased to announce the latest addition to our extensive line of pressure measurement products, the "Mini" gauge! This gauge has been developed to address the growing number of bio-pharmaceutical applications that require a smaller gauge dial and a fractional sanitary fitting. This new product meets both criteria with its low profile 2.5" (63mm) case and standard 3/4" Tri-Clamp® fitting.

The gauge is designed for use at process temperatures up to 140°C(284°F) and to withstand repeated in-line sterilization at up to 149°C(300°F). Our new back access re-zero adjustment is a standard feature on all models.

When ordered with the Anderson CPM fitting, the gauge is autoclaveable at 149°C(300°F) for one hour.

The "Mini" gauge is also the only sanitary gauge

available with a true one-inch tri-clamp fitting, eliminating the long standing problem of instrumenting one-inch lines. This unique fitting will accept a one-inch gasket without impinging on the diaphragm.

Complete specifications and ordering information are available on the reverse. For more information please visit our Web Site at [www.andinst.com](http://www.andinst.com), or contact your local Authorized Anderson Distributor.

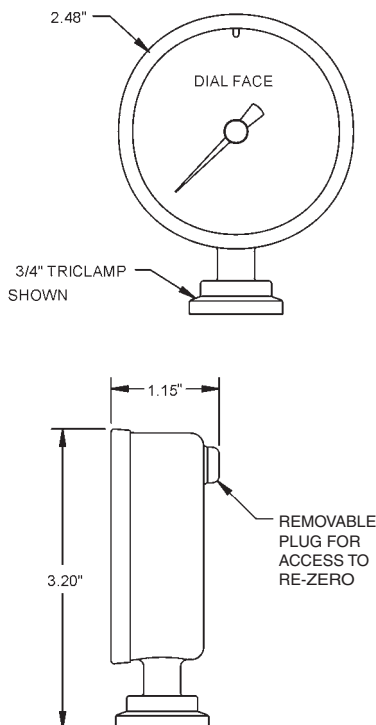

# Complete Product Ordering Matrix

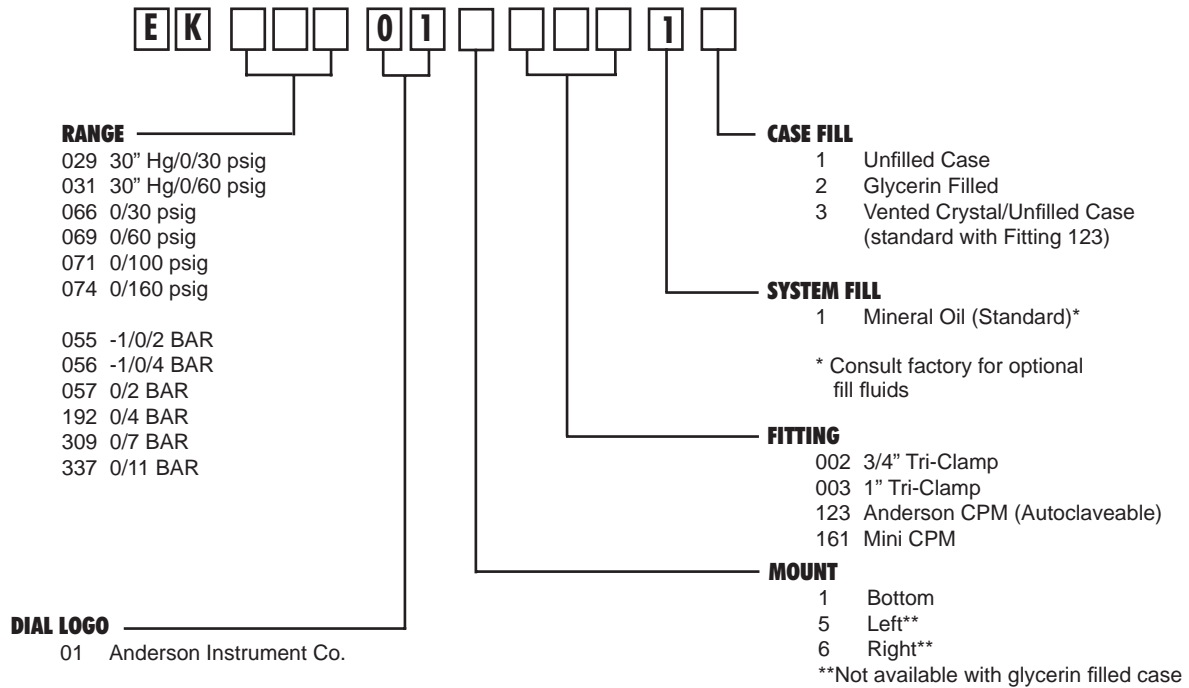

## "Mini" Gauge Specifications

### Typical Performance

Over-Range Capability:	at least 25% of full scale
Accuracy:	± 1.5% F.S. from 10-90% of scale (pressure ranges) ± 1.5% F.S. from 10-90% of pressure range, ±2.0" Hg from 0-25" Hg (compound ranges)
Repeatability:	± .50% of full scale
Linearity:	± .50% of full scale
Hysteresis:	± .50% of full scale
Stability:	Within specified accuracy for 6 months under normal operating conditions
Process Temperature Limits:	-3° to 140°C (25° to 284°F)
Ambient Temperature Limits:	4° to 49°C (40° to 120°F)
In-line Steam Sterilization Limits:	149°C (Up to 300°F) for 1 hour
Temperature Effect:	From 10-90% of pressure scale, less than ±1.25% F.S. per -12°C (10°F) change in process or ambient temperature
Autoclave Temperature Limit:	149°C (300°F) for 1 hour (CPM fitting and unfilled case only)

### Construction/Finish

Diaphragm and Fitting:	Welded 316 "L" grade stainless steel, electropolished to max. R <sub>a</sub> 8 micro-inches (0.2 microns)
Bourdon Tube/Socket:	304 stainless steel, welded
Movement:	Stainless steel
Case/Bezel:	304 stainless steel, satin finish to R <sub>a</sub> max = 32 micro-inches
Lens/Crystal:	Lexan® polycarbonate
Actuating Fill:	100% mineral oil. Meets FDA requirements (21CFR, 172.878 and 178.3620(a))
Optional Case Fill:	100% USP grade Glycerin
Standards:	Designed and manufactured to sound engineering practices in accordance with Article 3.3 of the PED 97/23/EC
Environmental Rating:	NEMA 4X-IP66
<b>Dimensions</b>	
Case Diameter:	2.48" (63mm)
Overall Height:	3.20" (81mm)
Case Depth:	1.15" (31 mm)