



**FLOW  
LEVEL  
PRESSURE  
ANALYTICAL  
TEMPERATURE  
INSTRUMENTATION  
PASTEURIZATION CONTROLS**

## **"RZ2AU" Utility Positive Displacement Flowmeter**

- *Electronic sensing of rotary piston eliminates all rotating shafts and seals found in industrial meters*
- *± .15% accuracy over flow range*
- *One moving part eliminates regular maintenance needs*

Anderson's RZU series flowmeter is a utility version of the industry accepted Accurate RZ series sanitary flowmeter. A lack of polish has made this rugged design suitable for use on corn sweeteners, oils and other products which do not require a 3A approved flowmeter. The RZ2AU provides the same single moving part design and the same high accuracy performance of its sanitary counterpart making it an attractive replacement for maintenance prone mechanical meters. Measurement is based on the principle of a chamber and rotating piston which create several internal chambers which are alternately filling and emptying as the piston moves in a

circular path within the chamber, sensing of the pistons position and movement provides the information necessary to measure the exact volume of liquid which has passed through the flowmeter. Measuring accuracy of  $\pm .15\%$  over operational range is achieved through quality manufacturing of a proven precision design. Coupling the simplicity of the measuring chamber with a fully electronic transducer, the RZ2AU can provide years of maintenance free, accurate service.

For more information on this flowmeter, or any of our Accurate flow products, visit [www.andinst.com](http://www.andinst.com) or call our Customer Service Department at 1-800-833-0081.

### **APPLICATIONS**

- *Water*
- *Corn Syrup*
- *High Fructose  
Corn Syrup*
- *Molasses*
- *Vegetable/Edible Oils*

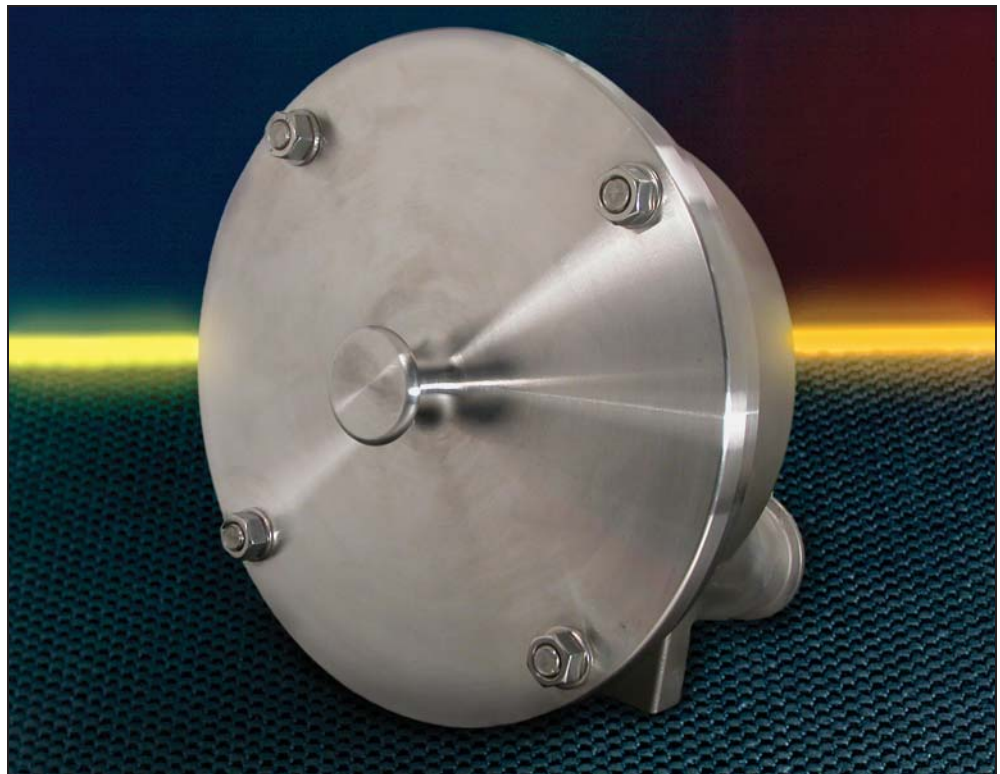

# RZ2AU Specifications

## Environmental Specifications

Power / Signal  
 Voltage: 12-24 VDC, 0.8 Watts  
 Signal Output: Unscaled, Pulsed Output - 11-22 VDC  
 Max. Output Frequency: No greater than 61Hz at maximum flow rate

## Operational Specifications

Flow Range on Water: 20 - 120 GPM  
 Accuracy: +0.15% Over Entire Flow Range  
 Repeatability: +0.05%  
 Maximum Product Temp: 200°F / 93°C  
 Maximum Inlet Pressure: 85 psi/5.9 bar  
 Maximum Allowable Pressure Drop: 45 psi/ 3.1 bar

## Material / Construction

Housing: 316L Stainless Steel  
 Piston: CIP-O-Plast (Food Grade Synthetic Polymer)  
 Wetted Parts: 316L Stainless Steel & CIP-O-Plast  
 Process Connection: 2" Tri-Clamp

## DIMENSIONS

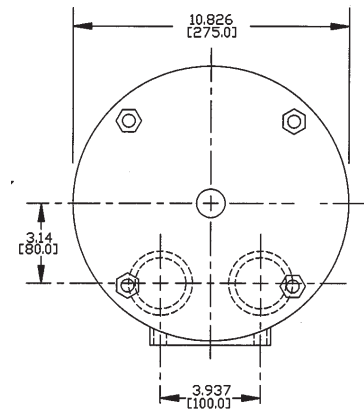
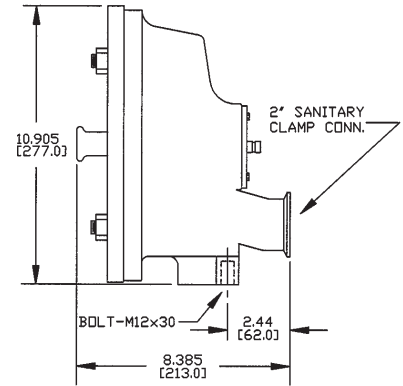

INCHES  
 [MILLIMETERS]  
 WEIGHT = 50 Lbs. [22.7 Kg.]

## METER FLOW RANGES

MODEL	METER SIZE	SANITARY CLAMP CONNECTION	TYPICAL FLOW RANGES IN GPM			
			WATER (1 cps)	LIGHT OILS (100 cps)	HFCS-55 (450 cps)	CORN SYRUP (5000 cps)
RZ-2AU	2"	2"	20-120	5-100	5-90	2-25

## HOW TO ORDER



**OUTPUT**  
 01 Transducer - 24 VDC  
 02 Transducer - Duty-Cycle Pulse Width - 24 VDC

**CABLE**  
 000 No cable\*  
 025 25' cable  
 050 50' cable  
 075 75' cable  
 100 100' cable

\* Use for cable lengths over 100'

## Replacement Parts

Part Number	Description
RZ32-2	2" CIP-O-Plast Piston
RZ32-92-24V	2" Transducer - 24VDC
RZ32-92-MPW24V	2" Transducer - Duty-Cycle Width 24VDC
0-265	2" Face Plate O-Ring